



## Actuators

## SQN13.xxxB9 SQN14.xxxB9

For air / gas dampers and control valves of oil or gas burners

---

### Electromotoric actuators

- Torque: Up to 1 Nm rated output torque
- Direction of rotation: - SQN13... Counterclockwise  
- SQN14... clockwise
- Running time for 90°: 5 ... 120 s depending on the type of basic unit (LMV2... / LMV3...)
- Versions: Choice of cables (refer to *Type summary*)

The SQN1... and this Data Sheet are intended for use by OEMs which integrate the actuators in their products!

---

### Use

The SQN1... actuators are used to drive and position air / gas dampers or other ancillary equipment.

When used in connection with burner controls or electronic fuel / air ratio control, the controlling elements are operated depending on the current burner output.

## Warning notes

---



**To avoid injury to persons, damage to property or the environment, the following warning notes must be observed!**

### **Do not to open, interfere with or modify the actuator!**

- All activities (mounting, installation and service work, etc.) must be performed by qualified staff
- Before making any wiring changes in the connection area of the actuator, completely isolate the plant from mains supply (all-polar disconnection). Ensure that the plant cannot be inadvertently switched on again and that it is indeed dead. If not observed, there is a risk of electric shock hazard
- Ensure protection against electric shock hazard by providing adequate protection for the connection terminals and by securing the housing cover
- Each time work has been carried out (mounting, installation, service work, etc.), check to ensure that wiring and parameterization is in an orderly state
- Fall or shock can adversely affect the safety functions. Such units must not be put into operation, even if they do not exhibit any damage
- The notes in chapter *Section of actuator version, Positive connection and Unambiguous assignment* must be observed, for safeguarding of correct fuel / air ratio

Housing cover

The actuator's housing **must not** be opened. The actuator features an optical feedback system.

## Selection of actuator version

---

- Select the type of actuator according to the direction of rotation required for adjusting the controlling element
- Ensure that any other torque acting on the controlling element (e.g. torque from airflow produced by the burner's fan) is smaller than the actuator's self-holding torque when dead
- The mechanical design of the burner must be such that any inadmissibly high torque from outside acting on the controlling element does not lead to any critical burner operation.  
Example: The airflow in the burner's air duct exerts a torque on the air damper's asymmetrical bearing, which means that the air damper will slightly travel toward the fully open position. This leads to a certain amount of excess air for combustion, which is less critical than lack of air

## Mounting notes

---

- Ensure that the relevant national safety regulations are complied with
- The connection between actuator drive shaft and controlling element must **be form-fitted with no mechanical play**
- The tightening torque of 1.5 Nm for the fixing screws (in the case of cut threads) must not be exceeded to prevent damage to the actuator and to ensure that the actuator does not twist on its mounting surface
- When mounting the actuator, ensure that the permissible axial and radial loads on the bearing are not exceeded
- When fitting the actuator to the controlling element, the correct mounting order must be observed. It is usually as follows:
  1. Screw on the actuator
  2. Connect the actuator's drive shaft to the controlling element using the coupling pin

### Positive connection



Possible connection with drive shaft or hub:

- Drive shaft with flat edge and matching counterpiece

To avoid inadmissible loads on bearings caused by rigid hubs, it is recommended to use compensating clutches with no mechanical play (e.g. metal bellows clutches).

- When sizing the drive shaft connection, consider that during operation the maximum torque can exceed the actuator's rated torque:
  - Under optimum conditions, the actuator itself can deliver a higher torque (up to 1.7 Nm)
  - Mass moments of inertia (produced by rotating parts of the motor and the controlling element) can lead to pulsating loads
- Siemens recommends to oversize the drive shaft connection in relation to the actuator's rated torque
- When fitting the actuator to the burner or the controlling element, ensure that bending cannot occur. This is of particular importance in the case of column structures

### Protection against overtravel (built-in end stops)

The actuator's working range is limited by built-in end stops. These are sized such that they withstand the maximum torques mentioned in paragraph *Positive connection* above.

### Unambiguous assignment



To prevent mix-up of the actuators connected to the LMV2... / LMV3..., these burner controls carry various reference marks. The burner must be designed such that, in the event of false connections, the relevant reference mark cannot be approached. For that purpose, mechanical stops are to be provided in the ranges *Stop open* and *Stop closed*.

### Cables

- The actuators are supplied with attached connecting cable and plug
- Single bend when laying the cable: 2 x cable diameter

## Mounting notes (cont'd)

Working range of actuator

The actuator's working range consists of usable range and reference range. The usable range of the actuator is shown on the type field. When mounting the actuator, the connected controlling element (e.g. air damper) must allow travel in the reference range and the adjusted usable range. The reference ranges *Open* and *Close* have different lengths. In the case of an actuator with **counterclockwise** rotation, reference range *Close* lies between  $0^\circ$  and  $-7.7^\circ$  and reference range *Open* between  $90^\circ$  and  $110.6^\circ$ .

Example of system with LMV2... / LMV3... and two SQN13...

Actuator 1, type SQN13..., air damper, referencing in the *Open* range:

- LMV2... / LMV3... parameter 601: 01: 1
- End stop in reference range *Close*

Actuator 2, type SQN13..., gas damper, referencing in the *Close* range:

- LMV2... / LMV3... parameter 601: 00: 0
- No end stop required

Direction of rotation  
**Counterclockwise**  
SQN13...

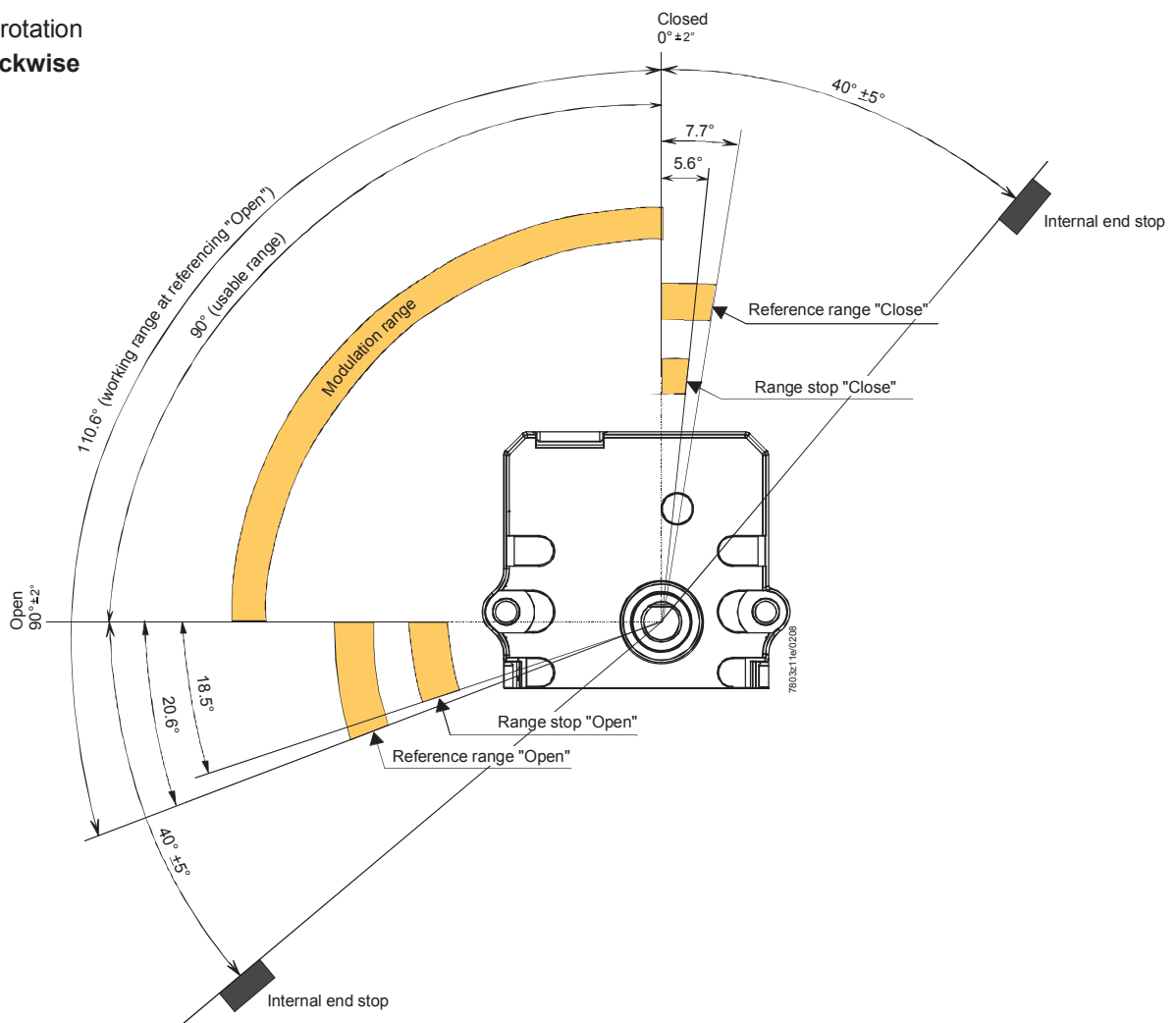

## Mounting notes (cont'd)

Direction of rotation  
**clockwise**  
 SQN14...

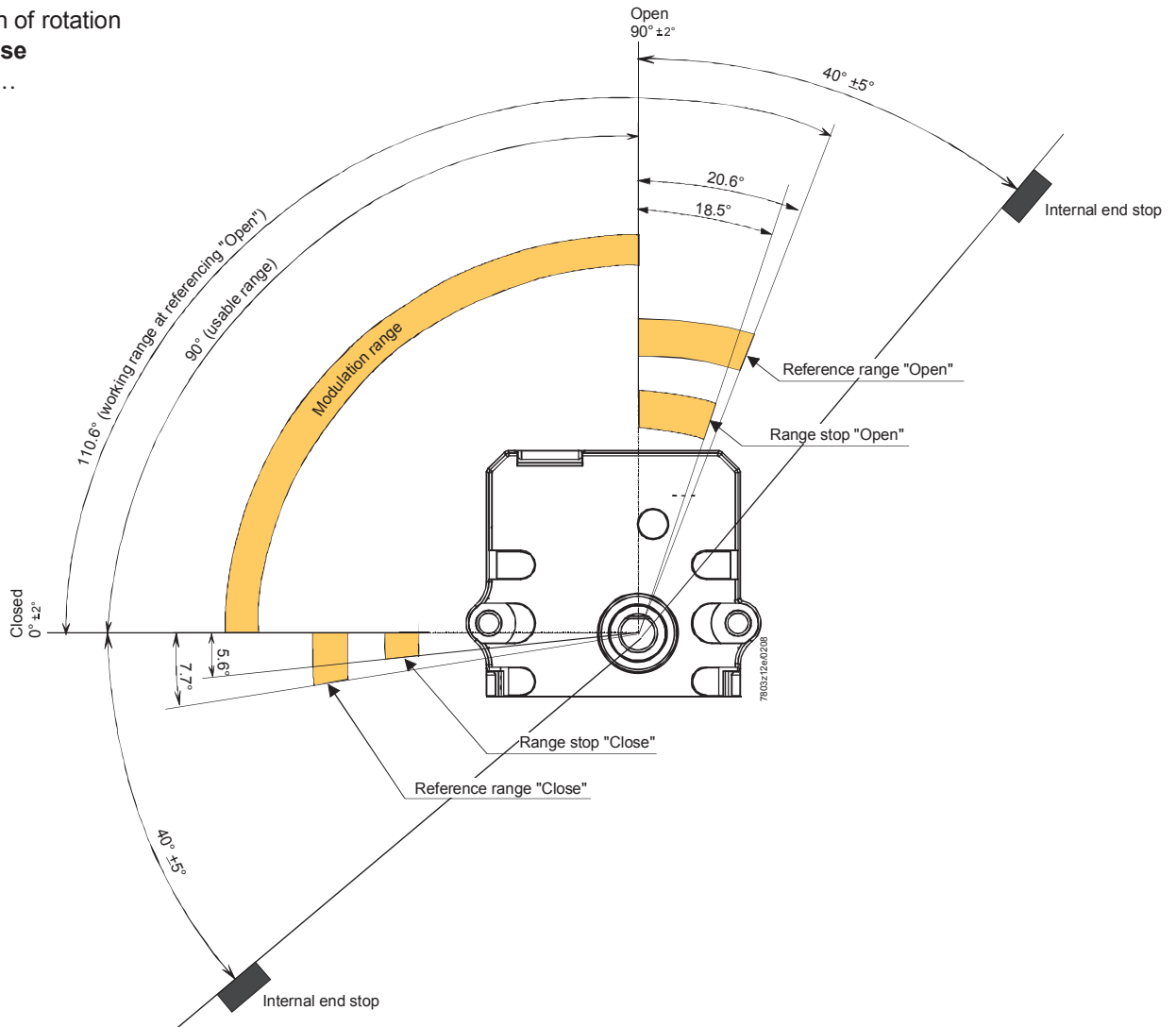

Turning the drive shaft  
 back to the working  
 position

If, due to external influences, the drive shaft leaves the working range without automatically returning after resetting the basic unit, it can be cautiously turned back manually.

To do this, disconnect power to the plant and drive the actuator cautiously to the beginning of the usable range.

During this action, the form-fitted connection between actuator and controlling element must be maintained.

Internal end stop



### Caution!

When turning the drive shaft back, make absolutely certain that mechanical loads do not damage the controlling element's built-in end stops since the actuator could leave its working range, making it impossible for the system to maintain the correct fuel / air ratio.

## Installation notes

---

- Always run the high-voltage ignition cables separate from the unit and other cables while observing the greatest possible distance
- The holding torque is reduced when the actuator is disconnected from power

## Standards and certificates

---



Conformity to EEC directives  
- Electromagnetic compatibility EMC (immunity)  
- Low-voltage directive

2004/108/EC  
2006/95/EC



ISO 9001: 2010  
Cert. 00739



ISO 14001: 2010  
Cert. 38233

## Service notes

---

Unit replacement	When replacing an actuator, the following points must be checked and, if necessary, corrected: <ul style="list-style-type: none"><li>• Correct connection of the basic unit</li><li>• Assignment of functions</li><li>• Adjustment of the curvepoints of electronic fuel / air ratio control (e.g. with the LMV2... / LMV3...)</li></ul>
------------------	--

## Disposal notes

---



The unit contains electrical and electronic components and must not be disposed of together with domestic waste.  
Local and currently valid legislation must be observed.

## Mechanical design

---

Housing	Base and cover are made of shockproof and heat-resistant plastic.  Color of housing and cover: Black
Actuator	Stepper motor
Adjustment of switching points / position indication	In connection with the basic unit, e.g. LMV2... / LMV3... via the AZL2... display and operating unit (refer to the Basic Documentation of the LMV2... P7541 / LMV3... P7546).
Cable / electrical connections	RAST2.5 connectors attached to the connecting cable, complete with cable gland.
Gear train	Backlash-free spur gears made of steel and plastic, with little backlash and permanent lubrication.
Drive shaft	Made of black-finished steel, ready fitted to the front of the gear train.
Mounting and fixing	Front fixing from the actuator side by means of 2 external fixing holes.

## Type summary

Product no.	Direction of rotation	Rated output torque in direction of rotation <i>Open</i> (max.) Nm	Holding torque when live (max.) Nm	Holding torque when dead (max.) Nm	Cable length m	Radial load on bearing <sup>1)</sup> (max.) N	Axial load on bearing (max.) N	Gear
<b>SQN13.140B9</b>	Counterclockwise	1	0.7	0.4	1.2	30	5	Metal
<b>SQN13.170B9</b>	Counterclockwise	1	0.7	0.4	1.2	30	5	Plastic
<b>SQN14.140B9</b>	Clockwise	1	0.7	0.4	1.2	30	5	Metal
<b>SQN14.170B9</b>	Clockwise	1	0.7	0.4	1.2	30	5	Plastic

<sup>1)</sup> Middle of drive shaft

## Technical data

Actuator	Supply voltage	AC / DC 24 V $\pm 20$ % (load on interface)
	Safety class	2 to EN 60730 part 1-14
	Power consumption	Max. 7.5 W
	Perm. on time	Max. 50 %
	Perm. running time	Max. 60 s
	Angular adjustment, usable range	Max. 90°
	Mounting position	Optional
	Load on bearing	Refer to <i>Type summary</i>
	Degree of protection	IP40 to EN 60529-1
	Direction of rotation	Cannot be selected on the LMV2... / LMV3..., but is given by the respective type of motor
	Rated output torque	Refer to <i>Type summary</i>
	Holding torque (when live)	Refer to <i>Type summary</i>
	Holding torque (when dead)	Refer to <i>Type summary</i>
	Rated resolution encoder monitoring	0.7°
	Running times	Adjustable on the LMV2... / LMV3...
	Load changes with continuous rated load	Typically 500,000
	Weight	Approx. 0.3 kg
	Direction of rotation (when facing the shaft)	
	- SQN13...	Counterclockwise
	- SQN14...	Clockwise
	0-position of actuator drive shaft	As supplied 0 +2° / -2°
	Perm. external mass of inertia	Max. 2 g/m <sup>2</sup>
	Perm. axial force of bearing	Max. 5 N
Cable connection	Connector	Duomodule RAST2.5 6-poles Supplied by Lumberg Part no. 3521 06 K00
	Environmental conditions	
Environmental conditions	<b>Storage</b>	IEC 60721-3-1
	Climatic conditions	Class 1K3
	Mechanical conditions	Class 1M2
	Temperature range	-20...+70 °C
	Humidity	<95 % r.h.
	<b>Transport</b>	IEC 60721-3-2
	Climatic conditions	Class 2K3
	Mechanical conditions	Class 2M2
	Temperature range	-20...+70 °C
	Humidity	<95 % r.h.
	<b>Operation</b>	IEC 60721-3-3
	Climatic conditions	Class 3K3
	Mechanical conditions	Class 3M3
	Temperature range	-10...+60 °C
	Humidity	<95 % r.h.



**Caution!**  
Condensation, formation of ice and ingress of water are not permitted!



## Function

The SQN1... actuators features an integrated reset spring with backlash-free gear train. The reset spring always acts against the actuator's direction of rotation. This ensures operation free from mechanical play. The drive shaft's torque must always act in the actuator's direction of rotation (e.g. with the SQN13... always counterclockwise). To ensure reliable operation, the torque in the other direction must not exceed 0.2 Nm when the connected air or gas damper closes. The same cable serves for control and position feedback. This cable is also used for the power supply. The actuators are driven by a stepper motor and can be positioned with a resolution of 0.1°. The characteristics and settings (running time, end positions) of the SQN1... are determined by the controlling basic unit (e.g. LMV2... / LMV3...; for details, refer to the Basic Documentation of the LMV2... P7541 / LMV3... P7546). The running times of the controlling elements are varied by the basic unit depending on the burner's control phase (e.g. startup phase: short running time; operation: long running time).

Example:  
SQN14... (clockwise)

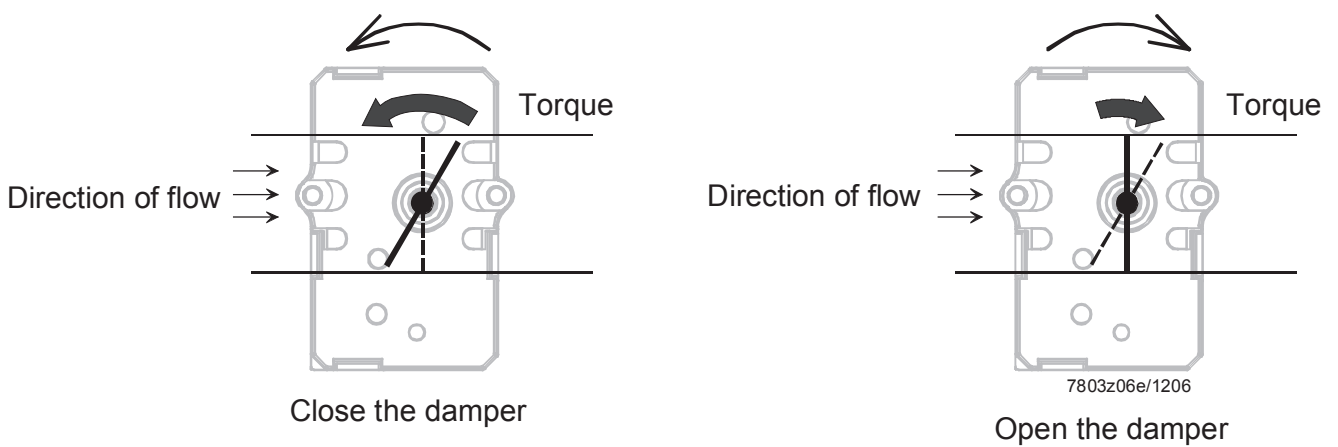

# Dimensions

Dimensions in mm

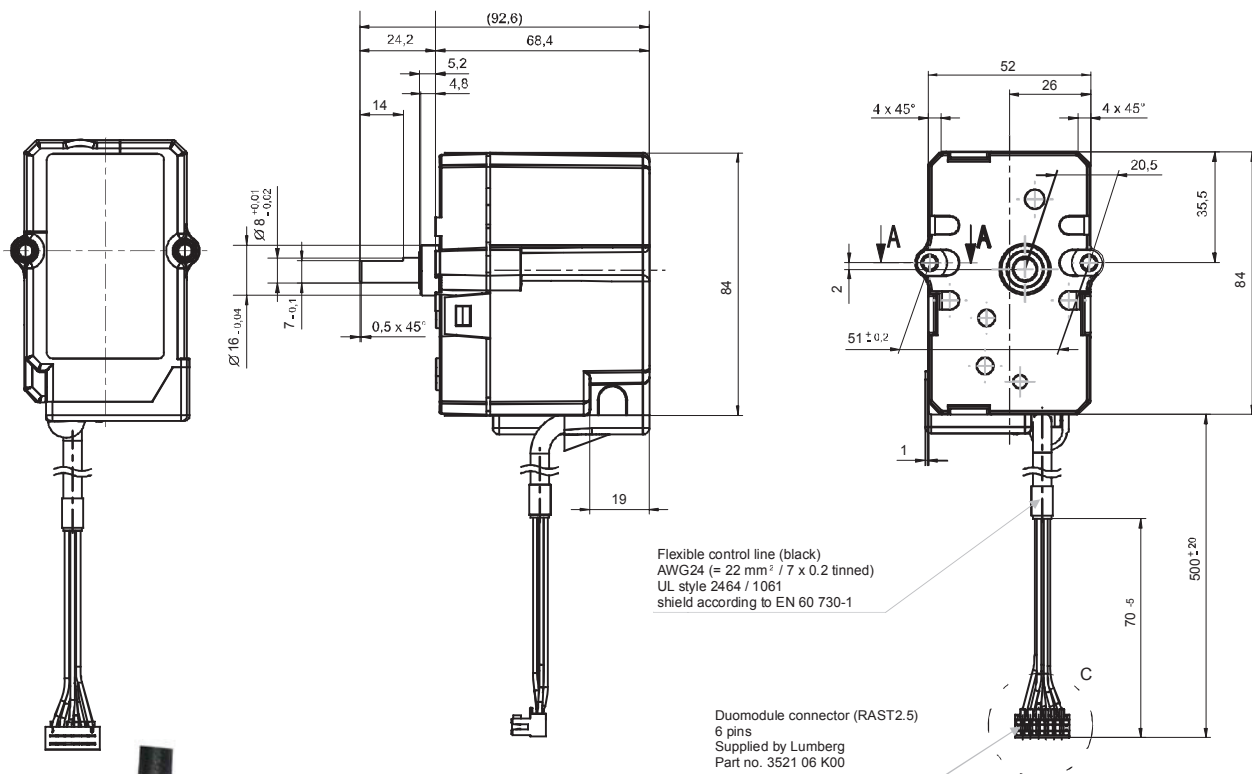

### Assignment of pins

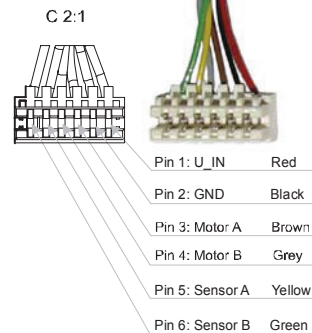

Brass tubing with through-hole  
 for hexagon socket head  
 cap screw M4 x...DIN 84

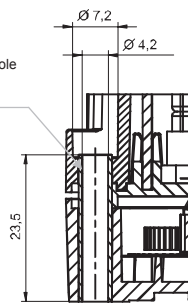

7803m01e/0209

Distributor: FLAME POWER SRL 021-3121727 ; 0744-340566 contact@arzatoare.ro ; www.arzatoare.ro

©2011 Siemens AG Industry Sector Building Technologies Division  
 Subject to change!