



LOA2...

LOA3...

Oil Burner Controls

**LOA2...
LOA3...**

**Oil burner controls for the supervision, startup and control of 1- or 2-stage forced draft oil burners in intermittent operation.
Oil throughput of less than 30 kg/h.**

The LOA2... / LOA3... and this Data Sheet are intended for use by OEMs which integrate the oil burner controls in their products.

Use, features

Use	<p>The LOA... are used for the startup, supervision and control of 1- or 2-stage forced draft oil burners in intermittent operation. Yellow-burning flames are supervised with photoresistive detectors QRB..., blue-burning flames with blue-flame detectors QRC...</p> <ul style="list-style-type: none"> - Forced draft oil burners conforming to EN 267 - Oil atomization burners in monoblock design conforming to EN 230: 1991
General features	<ul style="list-style-type: none"> - Undervoltage detection - Bridging contact for oil preheater (not with LOA28.173A27)
Specific features	<ul style="list-style-type: none"> - Special versions including models for incinerator plants and flash-steam generators - LOA36... with color display of flame intensity and operating

Warning notes



To avoid injury to persons, damage to property or the environment, the following warning notes must be observed!

Do not open, interfere with or modify the unit!

- All activities (mounting, installation and service work, etc.) must be performed by qualified staff
- Before making any wiring changes in the connection area, completely isolate the plant from mains supply (all-polar disconnection). Ensure that the plant cannot be inadvertently switched on again and that it is indeed dead. If not observed, there is a risk of electric shock hazard
- Ensure protection against electric shock hazard by providing adequate protection for the burner control's connection terminals. If not observed, there will be a risk of electric shock
- Each time work has been carried out (mounting, installation, service work, etc.), check to ensure that wiring is in an orderly state and make the safety checks as indicated in *Commissioning notes* above
- Press the lockout reset button / operating button only manually (applying a force of no more than 60 N), without using any tools or pointed objects. If not observed, the safety functions are no longer ensured and there will be a risk of electric shock
- Fall or shock can adversely affect the safety functions. Such units must not be put into operation, even if they do not exhibit any damage. If not observed, the safety functions are no longer ensured and there will be a risk of electric shock

Mounting notes

Ensure that the relevant national safety regulations are complied with.

Installation notes

- Always run high-voltage ignition cables separately while observing the greatest possible distance to the unit and to other cables
- Do not mix up live and neutral conductors
- Install switches, fuses, earthing, etc., in compliance with local regulations
- Ensure that the maximum permissible amperages will not be exceeded (see Technical data)

Electrical connection of flame detectors

It is important to achieve practically disturbance- and loss-free signal transmission:

- Never run the detector cable together with other cables
 - Line capacitance reduces the magnitude of the flame signal
 - Use a separate cable
- Observe the permissible lengths of the flame detector cables (see Data Sheets N7714 (QRB...) and N7716 (QRC...))
- Earth the burner in compliance with the relevant regulations; earthing the boiler alone does not suffice

Commissioning notes

When commissioning the plant, when carrying out maintenance work, or after longer off periods, make the following safety checks:

	Safety check to be carried out	Anticipated response
a)	Burner startup with flame detector darkened	Lockout at the end of «TSA»
b)	Burner startup with flame detector exposed to extraneous light	Lockout after approx. 40 seconds
c)	Simulation of flame failure during operation. For that purpose, darken the flame detector during operation and maintain this state	Repetition followed by lockout at the end of «TSA»

Standards and certificates



Conformity to EEC directives
- Electromagnetic compatibility EMC (immunity)
- Low-voltage directive

2004/108/EC
2006/95/EC



ISO 9001: 2008
Cert. 00739



ISO 14001: 2004
Cert. 38233

Service notes

Use the KF... service adapter for short periods of time only.

Life cycle

Burner controls LOA... has a designed lifetime* of 250,000 burner startup cycles which, under normal operating conditions in heating mode, correspond to approx. 10 years of usage (starting from the production date given on the type field).

This lifetime is based on the endurance tests specified in standard EN 230.

A summary of the conditions has been published by the European Control Manufacturers Association (Afecor) (www.afecor.org).

The designed lifetime is based on use of the burner controls according to the manufacturer's Data Sheet. After reaching the designed lifetime in terms of the number of burner startup cycles, or the respective time of usage, the burner control is to be replaced by authorized personnel.

* The designed lifetime is not the warranty time specified in the Terms of Delivery

Disposal notes



The unit contains electrical and electronic components and must not be disposed of together with domestic waste.

Local and currently valid legislation must be observed.

Mechanical design

The housing is made of impact-proof, heat-resistant and flame-retarding plastic.

The oil burner control is of plug-in design and engages audibly in its base. The color of plastic material of burner controls LOA... are executed in black.

The housing accommodates the

- thermal-electric sequence switch
- flame signal amplifier with the flame relay
- lockout reset button with its integrated fault indication lamp

Type summary

The type references given below apply to oil burner controls without base and without flame detector. For ordering information on plug-in bases and other accessories, refer to «Ordering».

Deliverable version	Type reference	Main voltage	Undervoltage detection	t1	t3	TSAmax.	t3n	t3n'	t4
Standard version	LOA24.171B27 ²⁾	AC 220 V	●	13 s	13 s	10 s	20 s	---	20 s
	LOA24.171B17 ²⁾	AC 110 V	●	13 s	13 s	10 s	20 s	---	20 s
	LOA24.173A27	AC 220 V	●	13 s	13 s	10 s	20 s	2 s	20 s
With remote reset facility	LOA26.171B27 ²⁾	AC 220 V	●	13 s	13 s	10 s	20 s	---	20 s
	LOA36.171A27	AC 220 V	●	13 s	13 s	10 s	20 s	---	20 s
For incinerator plant	LOA25.173C27 ¹⁾	AC 220 V	●	13 s	13 s	10 s	---	2 s	20 s
	LOA28.173A27 ¹⁾	AC 220 V	●	13 s	13 s	10 s	---	2 s	20 s

- Legend
- 1) LOA25... and LOA28... are designed for use on incinerator plant where lockout by extraneous light is not desired.
These types of oil burner controls are not covered by EN 230
- 2) IRD1010 infrared flicker detectors can also be used
- t1 Prepurge time
t3 Preignition time
t3n Long postignition time
t3n' Short postignition time
t4 Interval from establishment of flame to the release of «BV2»
TSAmax. Max. Ignition safety time

Oil burner control without plug-in base refer to «Type summary»

Connection accessories for small burner controls refer to Data Sheet N7201

- Plug-in base AGK11...
- Cable holders AGK65..., AGK66

Flame detectors

- Photoresistive detectors QRB1... refer to Data Sheet N7714
- Blue-flame detectors QRC1... refer to Data Sheet N7716

Demo case KF8891 Refer to Operating Instructions B7989

- For showing the functioning of burner controls



Pedestal AGK21 (empty housing)

- To increase the overall height of the LOA...to that of the LAI... / LAB...



Remote reset module ARK21A27

- For use with the LOA26... / LOA36... printed circuit board versions



Adapter KF8819

- For replacing LAB1... / LAI... by LOA...
- No rewiring of plug-in base required



Test adapter KF8833

- For checking the functions of burner controls on the burner
- With signal lamps for program indication
- With one pair of jacks for measuring the flame detector current



Test adapter KF8840

- For checking the functions of burner controls on the burner
- With signal lamps for program indication
- With on / off switch for simulating the flame signal
- With holes for checking the control voltages at the tabs of the burner control
- With one pair of jacks for measuring the flame detector's resistance

Test adapter KF8885

- For checking the functions of burner controls on the burner
- With switch for manual startup of burner
- With switch for simulating the oil preheater's release contact
- With 2 pairs of jacks for measuring the flame detector current
- Refer to Mounting Instructions B7986

Technical data

General unit data	Mains voltage	AC 220 V –15 %...AC 240 V +10 % AC 100 V –15 %...AC 110 V +10 %
	Mains frequency	50...60 Hz ±6 %
	External primary fuse (Si)	10 A (fast)
	Power consumption	Approx. 3 VA
	Perm. mounting position	Optional
	Weight	Approx. 180 g
	Degree of protection	IP40, must be ensured through mounting
	Safety class	I (burner control with plug-in base)
	Perm. cable lengths	Max. 3 m with 100 pF/m line capacitance
	- Detector cable laid separately	Max. 20 m
	- Remote reset laid separately	Max. 20 m
	Input current to	
	- Terminal 1	5 A (short-time 15 A for max. 0.5 s)
	- Terminal 3	5 A (excl. current draw of burner motor and oil preheater)

Perm. current at $\cos \varphi \geq 0.6$	Terminal 4	Terminal 5	Terminal 6	Terminal 7	Terminal 8	Terminal 10
LOA24.171B27	Max. 1 A	Max. 1 A	Max. 2 A	Max. 2 A	Max. 5 A	Max. 1 A
LOA24.171B17						
LOA25.173C27						
LOA28.173A27						
LOA24.173A27	Max. 1 A	Max. 1 A	Max. 2 A	Max. 1.5 A	Max. 5 A	Max. 1 A
LOA26.171B27	Max. 1 A	Max. 1 A	Max. 2 A	Max. 0.1 A	Max. 5 A	Max. 1 A
LOA36.171A27						

Environmental conditions

Storage	DIN EN 60721-3-1
Climatic conditions	Class 1K3
Mechanical conditions	Class 1M2
Temperature range	-20...+60 °C
Humidity	<95 % r.h.
Transport	DIN EN 60721-3-2
Climatic conditions	Class 2K2
Mechanical conditions	Class 2M2
Temperature range	-50...+60 °C
Humidity	<95 % r.h.
Operation	DIN EN 60721-3-3
Climatic conditions	Class 3K5
Mechanical conditions	Class 3M2
Temperature range	-20...+60 °C
Humidity	<95 % r.h.



Warning!

Condensation, formation of ice and ingress of water are not permitted!

If not observed, the safety functions are no longer ensured and there will be a risk of electric shock.

Technical data (cont'd)

Flame supervision with QRB... or QRC...

For measuring circuits and detector cable lengths, refer to Data Sheets N7714 (QRB...) and N7716 (QRC...).

QRB...

Type of burner control	QRB... (typically)		
	Required detector current required (with flame)	Perm. detector current (without flame)	Detector current possible (with flame)
LOA24.171B27 / LOA24.171B17	Min. 70 μ A	Max. 5.5 μ A	Max. 210 μ A
LOA25.173C27			
LOA26.171B27			
LOA28.173A27			
LOA24.173A27	Min. 45 μ A	Max. 5.5 μ A	Max. 45 μ A
LOA36.171A27	Min. 70 μ A	Max. 5.5 μ A	Max. 900 μ A

QRC1...

Type of burner control	QRC... (typically)		
	Required detector current required (with flame)	Perm. detector current (without flame)	Detector current possible (with flame)
LOA24.171B27	Min. 70 μ A	Max. 5.5 μ A	Max. 110 μ A
LOA26.171B27			
LOA24.171B17	Min. 70 μ A	Max. 5.5 μ A	Max. 90 μ A
LOA25.173C27 ¹⁾	---	---	---
LOA28.173A27 ¹⁾	---	---	---
LOA24.173A27	Min. 45 μ A	Max. 5.5 μ A	Max. 45 μ A
LOA36.171A27	Min. 70 μ A	Max. 5.5 μ A	Max. 110 μ A

¹⁾ These types of LOA... must not be used in connection with QRC...blue-flame detectors

Data given in the above table only apply under the following conditions:

- Mains voltage depending on version AC 110 V or AC 230 V
- Ambient temperature 23 °C

Measuring circuit for detector current

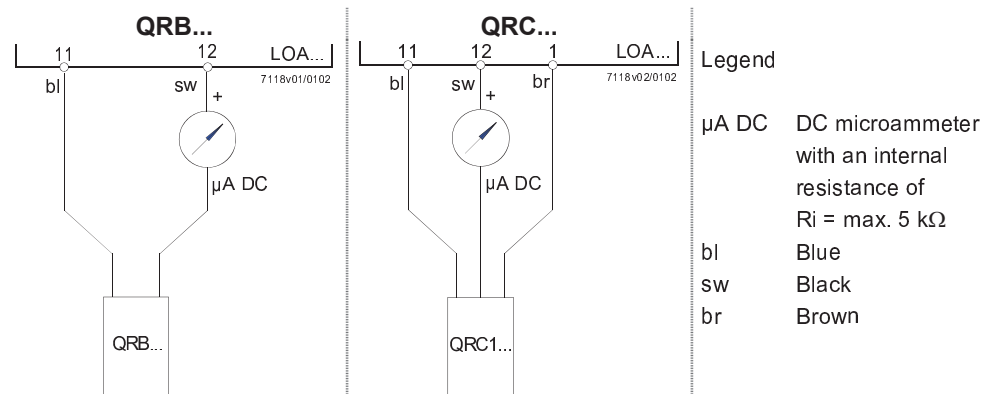

Only with LOA36...
Indication of flame strength

Detector current LED on

- With QRB... Min. 60 μ A $\pm 15 \%$
- With QRC... Min. 40 μ A $\pm 15 \%$



Function

Preconditions for startup	<ul style="list-style-type: none"> • Burner control is reset • Contacts in the line are closed, heat demand • No undervoltage • Flame detector is darkened, no extraneous light
Undervoltage detection	An additional electronic circuit ensures that if mains voltage drops below approximately AC 165 V, burner startup will be prevented, or – without release of oil – lockout will be triggered.
Control sequence in the event of fault	<p>Whenever lockout occurs, the outputs for the fuel valves, the burner motor, oil preheater and ignition equipment will immediately be deactivated (<1 second). The lockout indication lamp lights up red and terminal 10 («AL») for remote lockout indication receives voltage.</p> <p>This state is also maintained in the event of mains voltage failure.</p>

Cause	Response
Mains voltage failure	Restart
Extraneous light on burner startup	Lockout; with LOA25... / LOA28...: Prevention of start
No flame at the end of «TSA»	Lockout
Loss of flame during operation	Repetition

Reset of burner control	After lockout, the burner control can be reset after 60...90 seconds (also refer to «Warning notes»).
-------------------------	---

Indications

Lockout position	The lockout position is indicated with the lamp integrated in the lockout reset button.
Flame strength	Only with LOA36...
	<p>Indication of the flame strength (green LED) is used for checking the flame signal. To ensure reliable burner operation, this LED must be lit.</p> <p>If the green LED flickers or extinguishes during burner operation, the light conditions at the burner are poor, caused by dirt for instance.</p>
Operation	Only with LOA36...
	When the contacts of the control thermostat are closed, the orange LED is lit, indicating the start of the oil preheater's heating up phase (if present).

**Connection diagram inclusive
internal diagram**

Control sequence

LOA24.171B27
LOA24.171B17

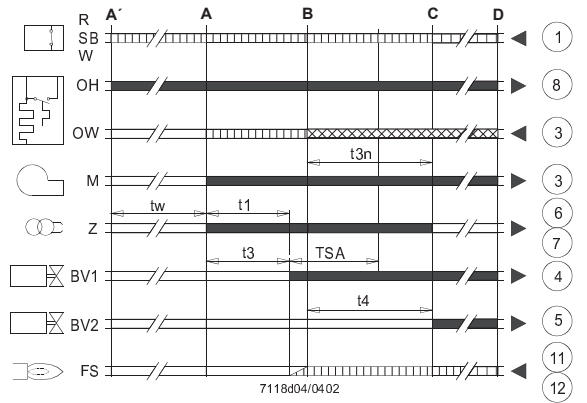
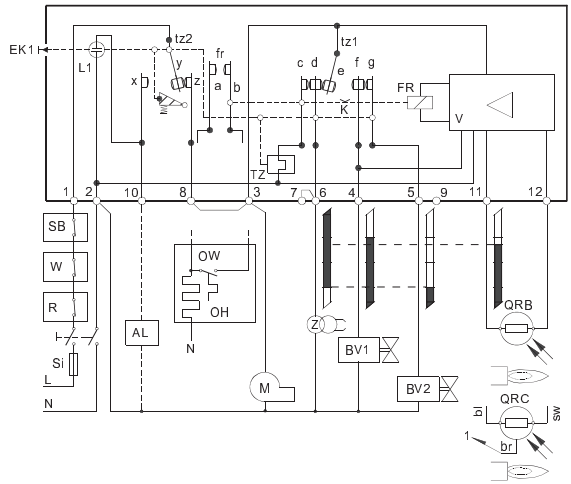

LOA24.173A27

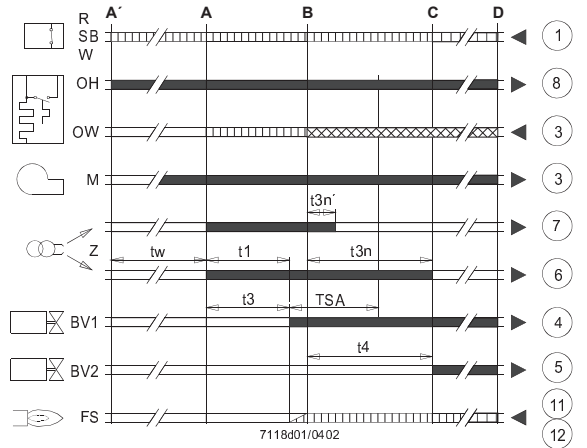
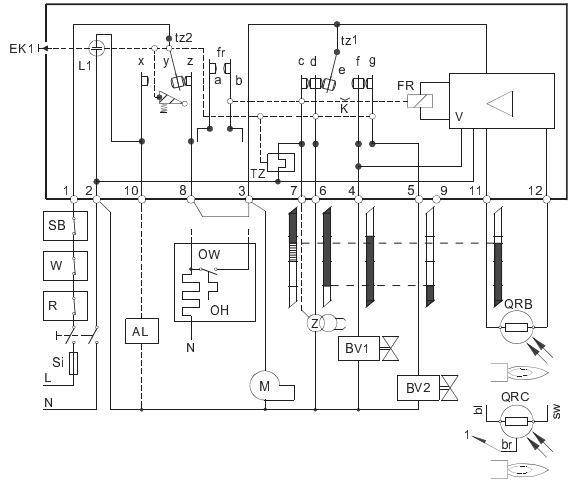

LOA25.173C27
LOA28.173A27

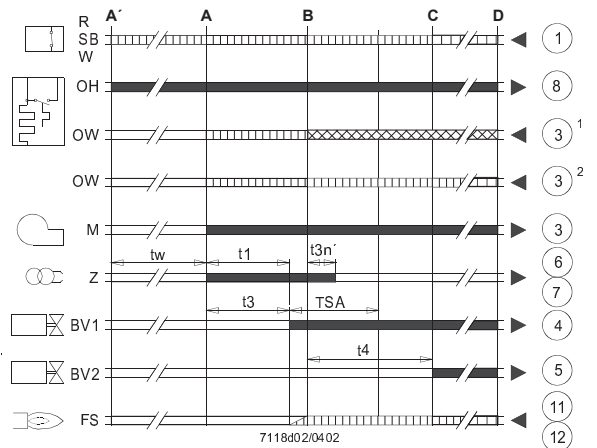
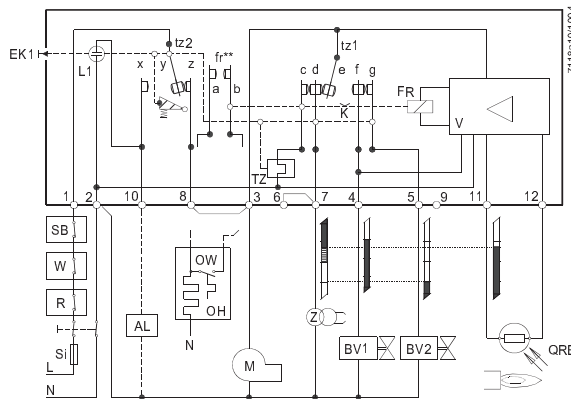

fr** Not provided with the LOA28.173A27

- 1) LOA25.173C27
- 2) LOA28.173A27

Connection diagram inclusive internal diagram

Control sequence

LOA26.171B27

With ARK21
remote lockout
reset module

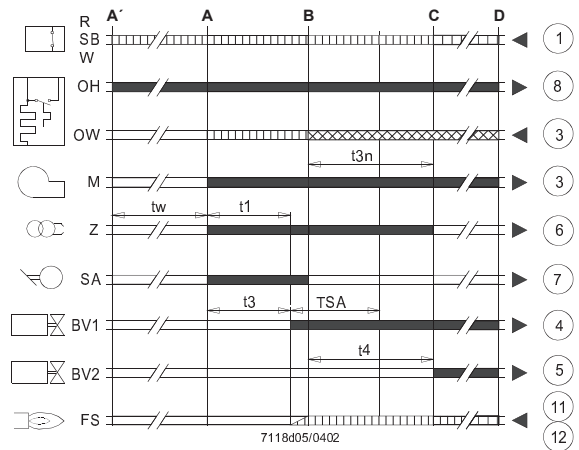
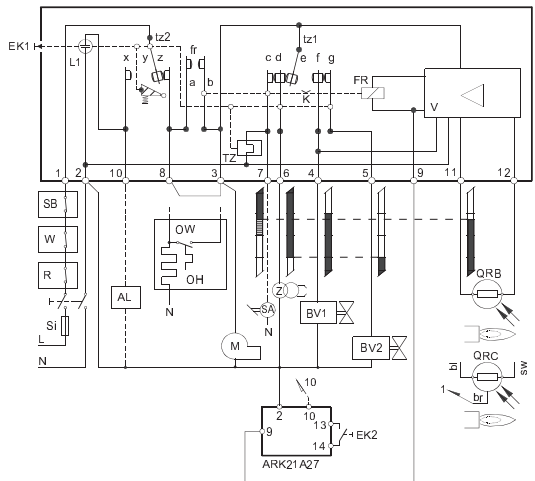

LOA36.171A27

With ARK21
remote lockout
reset module

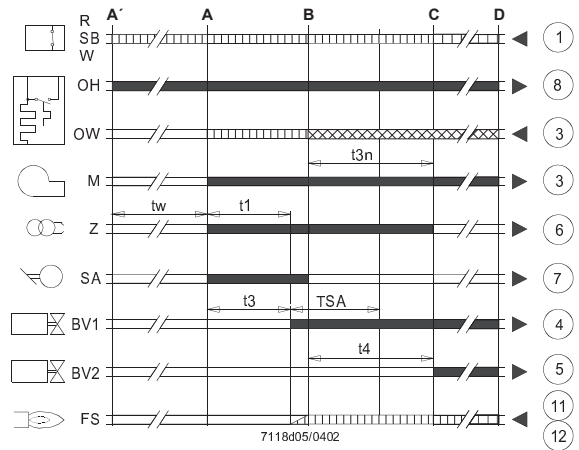
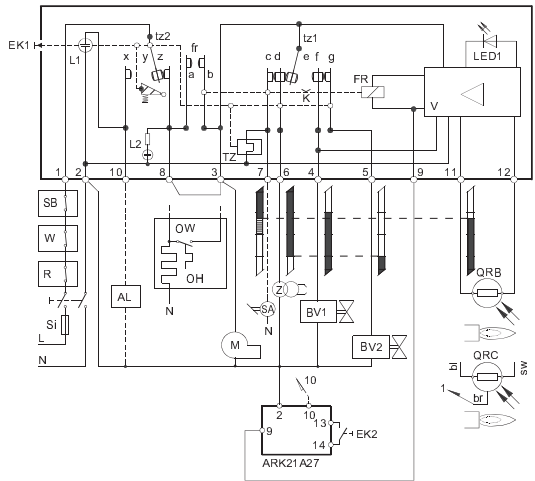

Legend

AL	Alarm device
BV...	Fuel valve
EK1	Lockout reset button
EK2	Remote lockout reset button
FR	Flame relay with contacts «fr»
fr	Bridging contact for release contact of «OH»
FS	Flame signal
K	Catch of flame relay for locking contact «tz1» in the event of premature flame signals or for locking the contact when the flame signal is correct
L1	Indication of faults (red)
L2	Indication of operation (orange)
LED1	Indication of flame strength (green)
M	Burner motor
TSA	Ignition safety time
tw	Waiting time
t1	Prepurge time
t3	Preignition time
t3n	Long postignition time
t3n'	Short postignition time
t4	Interval between flame signal and release of «BV2»

OW	Release contact of oil preheater
OH	Oil preheater
QRB...	Photoresistive detector
QRC...	Blue-flame detector
	bl = blue, br = brown, sw = black
R	Control thermostat or pressurestat
SA	Actuator with automatic setback
SB	Safety limit thermostat
Si	External primary fuse
TZ	Thermal-electric sequence switch
tz...	Contacts of «TZ»
W	Limit thermostat or pressure switch
V	Flame signal amplifier
Z	Ignition transformer

A'	Beginning of the startup sequence with burners using an «OH»
A	Beginning of the startup sequence with burners using no «OH»
B	Time of flame establishment
C	Running position
D	Controlled shutdown by «R»
■	Control signals delivered by the LOA...
▨	Required input signals
▩	Permissible input signals

Dimensions

Dimensions in mm

LOA...



Plug-in base AGK11...

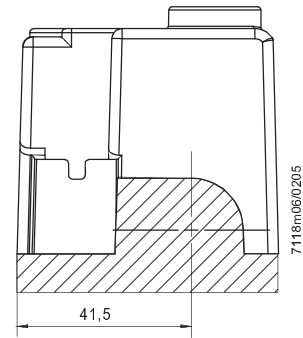
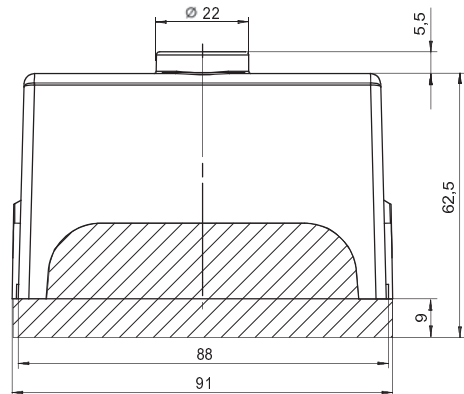

LOA2...

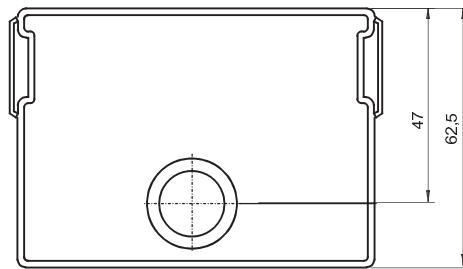

LOA3...

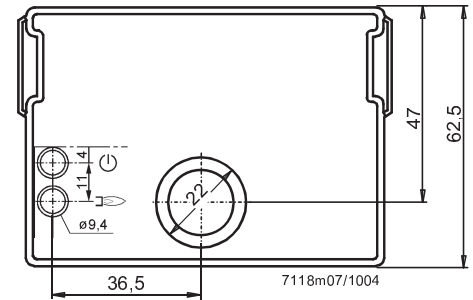

Status indication (orange)



Indication of flame strength (green)

Remote lockout reset
module ARK21A27

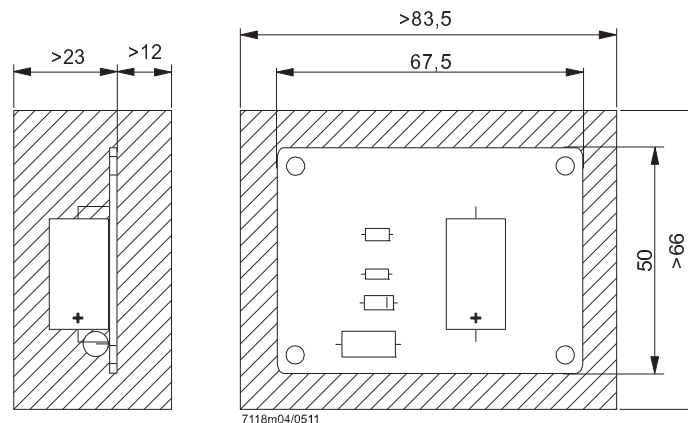

Remote lockout reset module for use with the LOA26... / LOA36...

Printed circuit board with no housing.

Degree of protection IP00, which means that protection against electric shock hazard, must be ensured through mounting.

Do not place any metal objects in the hatched area.

The module must be fitted with the help of spacers made of plastic.

Do not use spacers made of metal.

Distributor: FLAME POWER SRL 021-3121727 ; 0744-340566 contact@arzatoare.ro ; www.arzatoare.ro

© 2013 Siemens AG Infrastructure & Cities Sector Building Technologies Division

Subject to change!

11/11