



## Burner Controls

## LG16...

### Burner controls

- For use on industrial furnaces
- For burners in continuous operation
- Without fan control and air pressure supervision
- Flame supervision
  - with QRA53... / QRA55..., flame detector
  - with ionizations probe
- With self-supervising flame signal amplifier
- Quick startup
- 1-stage operation with interrupted pilot burner or 2-stage operation
- Common or separate ionization probe and ignition electrode (single- or double-electrode operation)
- Automatic restart (repetition) or lockout after loss of flame during operation
- Indication of program sequence
- Remote reset facility
- Programming mechanism in plastic housing, plugs into the base

The LG16... and this Data Sheet are intended for use by OEMs which integrate the burner controls in their products.

### Use

Supervision and control of oil or gas burners for use on industrial furnaces that operate continuously for longer periods of time (>24 hours) without controlled shutdown.

#### Flame supervision

- QRA53... / QRA55... flame detector
- Ionization probe
- QRA53... / QRA55... flame detector and ionization probe together, e.g. with burner with ignition burner, refer also to Data Sheet N7712

## Warning notes

---



**To avoid injury to persons, damage to property or the environment, the following warning notes must be observed!**

**Do not open, interfere with or modify the unit!**

- All activities (mounting, installation and service work, etc.) must be performed by qualified staff
- Before making any wiring changes in the connection area, completely isolate the plant from mains supply (all-polar disconnection). Ensure that the plant cannot be inadvertently switched on again and that it is indeed dead. If not disconnected, there is a risk of electric shock hazard
- Ensure protection against electric shock hazard by providing adequate protection for the burner control's terminals
- Each time work has been carried out (mounting, installation and service work, etc.), check to ensure that wiring is in an orderly state and make the safety checks as described in «Commissioning notes».
- Press the lockout reset button / operation button only manually (applying a force of no more than 10 N), without using any tools or pointed objects
- **Do not press the lockout reset button on the unit or the remote reset button (input 21) for more than 10 seconds, since this would damage the lockout relay inside the unit**
- Fall or shock can adversely affect the safety functions. Such units must not be put into operation, even if they do not exhibit any damage

## Mounting notes

---

- Ensure that the relevant national safety regulations are complied with

## Installation notes

---

- Always run the high-voltage ignition cables separately while observing the greatest possible distances to the unit and to other cables
- Do not mix up live and neutral conductors
- Install switches, fuses and earthing, in compliance with local regulations
- Make certain that the maximum permissible current rating of the connection terminals will not be exceeded



### Caution!

- **Observe the polarity**  
**Burner controls LGI16... are not able to detect wrong polarity of live and neutral conductors**

- When used in connection with UV detector QRA53... / QRA55..., terminal 22 must be earthed
- For repetitive operation, remove wire link «J» between terminals 8 and 11 in base AGM15



### Warning!

- **Danger - high voltage**  
**In single-electrode operation, measurement of the ionization current is not possible. During the ignition times, the ionization current path carries high voltage.**

## Electrical connection of flame detectors

It is important to achieve practically disturbance-free signal transmission:

- Never run the detector cable together with other cables
  - Line capacitance reduces the magnitude of the flame signal
  - Use a separate cable
- Observe the permissible length of the detector cables (refer to «Technical data»)
- It is not permitted to connect 2 flame detectors QRA53... / QRA55... in parallel
- When using the QRA53... / QRA55..., earthing of terminal 22 is mandatory
- The ionization probe does not offer protection against electric shock hazard
- Locate the ignition electrode and ionization probe such that the ignition spark cannot arc over to the ionization probe (risk of electrical overloads) and that it cannot adversely affect the supervision of ionization
- Supervision with ionization probe and QRA53... / QRA55... flame detector is possible but, for safety reasons, both must not be active at the same time, with the exception of the second safety time «t9». At the end of the second safety time, one of the detected flames must extinguish, e.g. by shutting down the pilot gas valve connected to terminal 17
- For cable lengths, refer to «Technical data», section «Detector and flame supervision»
- Insulation resistance
  - Must be a minimum of 50 MΩ between ionization probe and ground
  - Soiled detector holders reduce the insulation resistance, thus supporting creepage currents
- Earth the burner in compliance with the relevant regulations; earthing the boiler alone does not suffice

## Commissioning notes

- When commissioning the plant or when doing maintenance work, make the following safety checks:

	Safety check	Anticipated response
a)	Burner startup with flame detector darkened	Lockout at the end of safety time (TSA)
b)	Burner startup with flame detector exposed to extraneous light	Lockout after no more than 40 seconds
c)	Burner operation with simulated loss of flame; for that purpose, darken the flame detector during operation	Restart followed by lockout at the end of safety time (TSA) if wire link (J) (terminals 8...11) is removed, otherwise immediate lockout

## Standards and certificates



Conformity to EEC directives

- Electromagnetic compatibility EMC (immunity)
- Low-voltage directive
- Directive for gas-fired appliances

2004/108/EC

2006/95/EC

2009/142/EC



ISO 9001: 2008  
Cert. 00739



ISO 14001: 2004  
Cert. 38233



Identification code to EN 298

A B L / C L X K

## Service notes

---

- UV detector current measuring unit KF8832 is not suited for continuous operation

## Life cycle

---

Burner control have a designed lifetime\* of 250,000 burner startup cycles which, under normal operating conditions in heating mode, correspond to approx. 10 years of usage (starting from the production date given on the type field).

This lifetime is based on the endurance tests in the standard EN 230 / EN 298. A summary of the conditions has been published by the European Control Manufacturers Association (Afecor) ([www.afecor.org](http://www.afecor.org)).

The designed lifetime is based on use of the burner controls according to the manufacturer's Data Sheet. After reaching the designed lifetime in terms of the number of burner startup cycles, or the respective time of usage, the burner control is to be replaced by authorized personnel.

\* The designed lifetime is not the warranty time specified in the Terms of Delivery

## Disposal notes

---



The unit contains electrical and electronic components and must not be disposed of together with household waste.

Local and currently valid legislation must be observed.

## Mechanical design

---

LGI16...

- Plug-in design
- Exchangeable unit fuse (including spare fuse)
- Impact-proof plastic housing
- Synchronous drive motor
- Lockout relay with electric, remote reset facility
- Self-supervising electronic flame signal amplifier with flame relay
- Program indication in the viewing window by means of disk on the spindle of the sequence switch (refer to «Control and function diagram»)
- Lockout warning lamp in the viewing window
- Reset after lockout by slightly pressing on the viewing window
- Printed circuit board with electronic components
- Programming mechanism with fixed settings

Housing

- Made of impact-proof and heat-resistance black plastic
- Lockout reset button with viewing window; located behind it:
  - Lockout warning lamp
  - Lockout indicator
    - coupled to the spindle of the sequence switch
    - visible in the transparent lockout reset button
    - uses easy-to-remember symbols to indicate the type of fault and the point in time lockout occurred

## Ordering

---

**Burner control**, without plug-in base

- AC 220...240 V

**LGI16.053A27**

- AC 100...110 V

**LGI16.053A17**

Plug-in base is not included in standard delivery, must be ordered as a separate item!

**Accessories for medium-capacity burner controls**

refer to Data Sheet N7230

- Plug-in base **AGM15** with Pg11 thread for cable entry glands

- Plug-in base **AGM15.1** with M16 thread for cable entry glands

**Flame detector**

- UV detector QRA53... / QRA55...

refer to Data Sheet N7712

- Ionizations probe

supplied by the burner manufacturer



**UV detector current measuring instrument**

**KF8832**

- Only for measurements of short duration

- Not suited for continuous operation



**Caution!**

**The KF8832 negates the self-supervision function.**

## Technical data

General unit data	Mains voltage	AC 220 V –15 %...AC 240 V +10 % AC 100 V –15 %...AC 110 V +10 %
	Mains frequency	50...60 Hz ±6 %
	Unit fuse, built-in	T6,3H250, DIN EN 60 127 (5 x 20 mm)
	External primary fuse	Max. 16 A, slow
	Weight	Approx. 1,000 g
	Power consumption	Approx. AC 3.5 VA
	Perm. mounting position	Optional
	Degree of protection	IP40, when fitted, with the exception of the connection area (terminal base)
	Safety class	II
	Perm. input current at terminal 1	Max. 5 A (peaks of 20 A / 20 ms)
	Perm. current load on control terminals	Max. 4 A (peaks of 20 A / 20 ms)
	Required switching capacity of the switching devices connected to terminals 4 and 5	Depending on the loads connected to terminals 16...19 Min. 1 A, AC 250 V

## Detector and flame supervision

	QRA5x.C... QRA5x.E...	QRA5x.D... QRA5x.G...	Ionization probe
Operating voltage	AC 280 V <sup>1)</sup> ±10 %	AC 280 V <sup>1)</sup> ±10 %	AC 245 V <sup>1)</sup> ±10 %
Min. detector current required	DC 35 µA	DC 120 µA	DC 12 µA
Max. detector current possible	DC 50 µA	DC 270 µA	DC 100 µA
Short-circuit current	---	---	ca. AC 300 µA
Max. length of detector cable, laid separately	<sup>2)</sup>	<sup>2)</sup>	60 m
Mounting position	Optional	Optional	---

- 1) Alternating current, measured with no detector current at AC 110V / AC 230 V mains voltage.  
Internal resistance of measuring instrument: 10 MΩ.  
Shutter drive of UV detector QRA53... / QRA55... operates on mains voltage
- 2)
  - Detector cable laid at a distance of at least 50 mm from other mains carrying cables:
    - As a multicore cable: max. 50 m
    - With 5 single wires: max. 70 m
  - Detector cable laid directly adjacent to other mains carrying cables:
    - With shielded 3-core control cable connected to pins 3, 4 and 5 of the QRA53... / QRA55...; for the mains connection (pins 1 and 2), a normal mains cable can be used max. 15 m
    - With 3 screened 3-core coaxial cables (93 Ω; 45 pF/m) connected to pins 3, 4 and 5 of the QRA53... / QRA55...; for the mains connection (pins 1 and 2), a normal mains cable can be used max. 60 m
    - If possible, connect cable shielding at both ends of the cable

## Technical data (cont'd)

Environmental conditions	<b>Storage</b>	DIN EN 60721-3-1
	Climatic conditions	class 1K3
	Mechanical conditions	class 1M2
	Temperature range	-20...+60 °C
	Humidity	<95 % r.h.
	<b>Transport</b>	DIN EN 60 721-3-2
	Climatic conditions	class 2K2
	Mechanical conditions	class 2M2
	Temperature range	-40...+60 °C
	Humidity	<95 % r.h.
	<b>Operation</b>	DIN EN 60 721-3-3
	Climatic conditions	class 3K5
Mechanical conditions	class 3M2	
Temperature range	-20...+60 °C	
Humidity	<95 % r.h.	



**Caution!**  
Condensation, formation of ice and ingress of water are not permitted!

## Detector current measurement

LG16... / QRA53... /  
QRA55...

Use the KF8832 measuring device (not suited for continuous operation).  
There is no self-checking while measurements are made.  
The KF8832 is not required when using the QRA5x.D... / QRA5x.G...

With QRA5x.C...

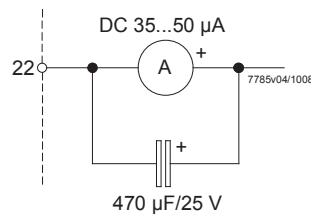

With QRA5x.D...

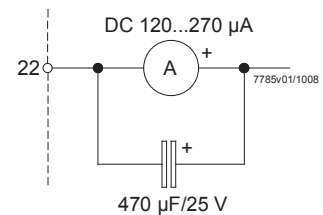

With QRA5x.E...

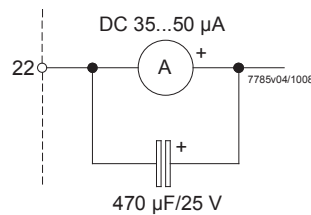

With QRA5x.G...

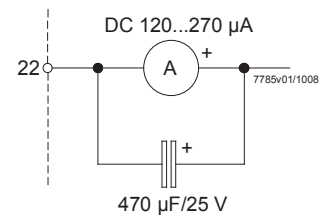

## Detector current measurement (cont'd)

LGI16... / ionization probe

The measuring device must be connected between terminal 24 and the detector electrode (+pole to terminal 24).

With ionization

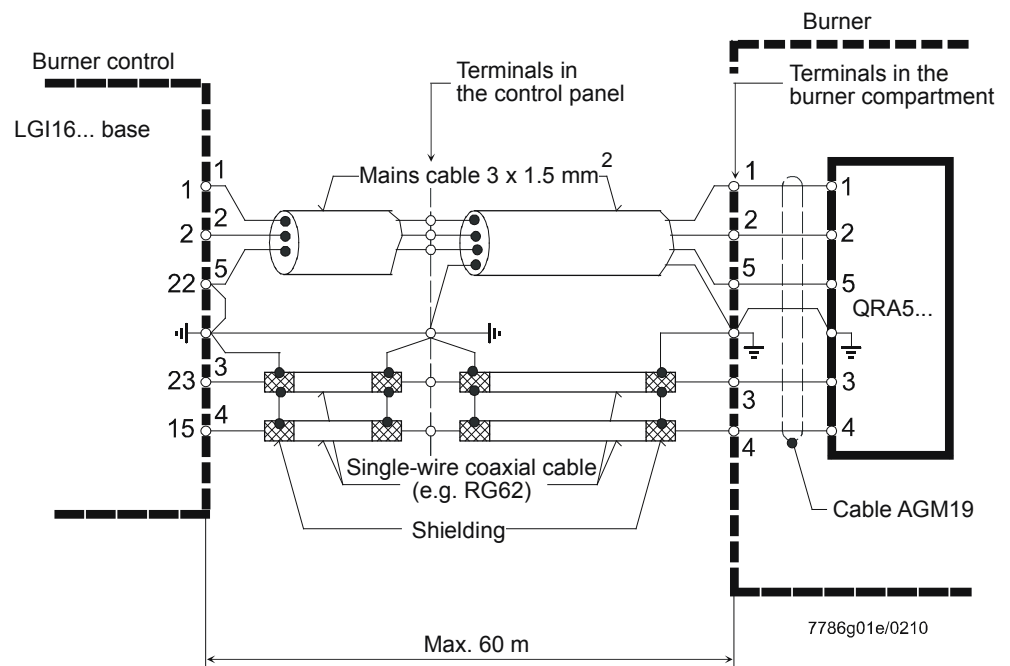
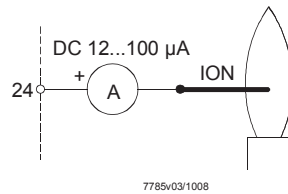

Legend

A	Ammeter
QRA5...	Flame detector
ION	Ionization probe



## Function

Program sequence	<p>When power is supplied to the burner control and the control loop (terminals 4 and 5) is closed, the LGI16... will start the program sequence as shown in «Control and function program», the most important program steps being the following:</p> <ul style="list-style-type: none"><li>• Waiting time<ul style="list-style-type: none"><li>– No external function</li><li>– Internal flame simulation test</li></ul></li><li>• Release of ignition</li><li>• Release of pilot gas valve<ul style="list-style-type: none"><li>– Establishment of pilot flame during the first safety time (TSA)</li><li>– Release of gas valve stage 1</li></ul></li><li>• Release of gas valve stage 1<ul style="list-style-type: none"><li>– Establishment of pilot flame during the first safety time (TSA)</li><li>– Release of gas valve stage 2</li><li>– Establishment of main flame during the second safety time (t9)</li></ul></li><li>• Burner operation The burner control maintains its operating position and continuously checks the presence of flame</li><li>• Shutdown when the control loop between terminals 4 and 5 opens. The signal to the gas valves will immediately be cut off. During the time home run (t20), the programming mechanism returns to its start position</li></ul>
Control program in the event of fault	<ul style="list-style-type: none"><li>• Flame signal on startup causes the burner control to initiate lockout</li><li>• No flame signal at the end of the first or second safety time causes the burner control to initiate lockout</li><li>• Loss of flame during operation Wire link «J», between terminals 8...11 in the base<ul style="list-style-type: none"><li>– Wire link fitted: burner control will initiate lockout</li><li>– Without wire link: burner control will automatically execute a restart (repetition)</li></ul></li></ul> <p>Base AGM15 is supplied with wire link «J» fitted.</p> <p>In the event of lockout, the signals to the gas valves will be cut off in less than one second and the burner control locked. Resetting is always to be made manually by pressing lockout reset button «EK1» or «EK2».</p> <p>In the case of repetition, the signals to the gas valves will also be cut off in less than one second. Then, the programming mechanism will automatically return to its start position (home run) to make a new start.</p>
Common ignition probe and ionization electrode	<p>(Single-electrode operation, ionization probe, connected to terminal 7)</p> <p>In the period between the ignition time (tz) and the end of the first safety time (TSA), the secondary side of the ignition transformer is switched from earthing to the flame signal amplifier.</p>

Control and function diagram

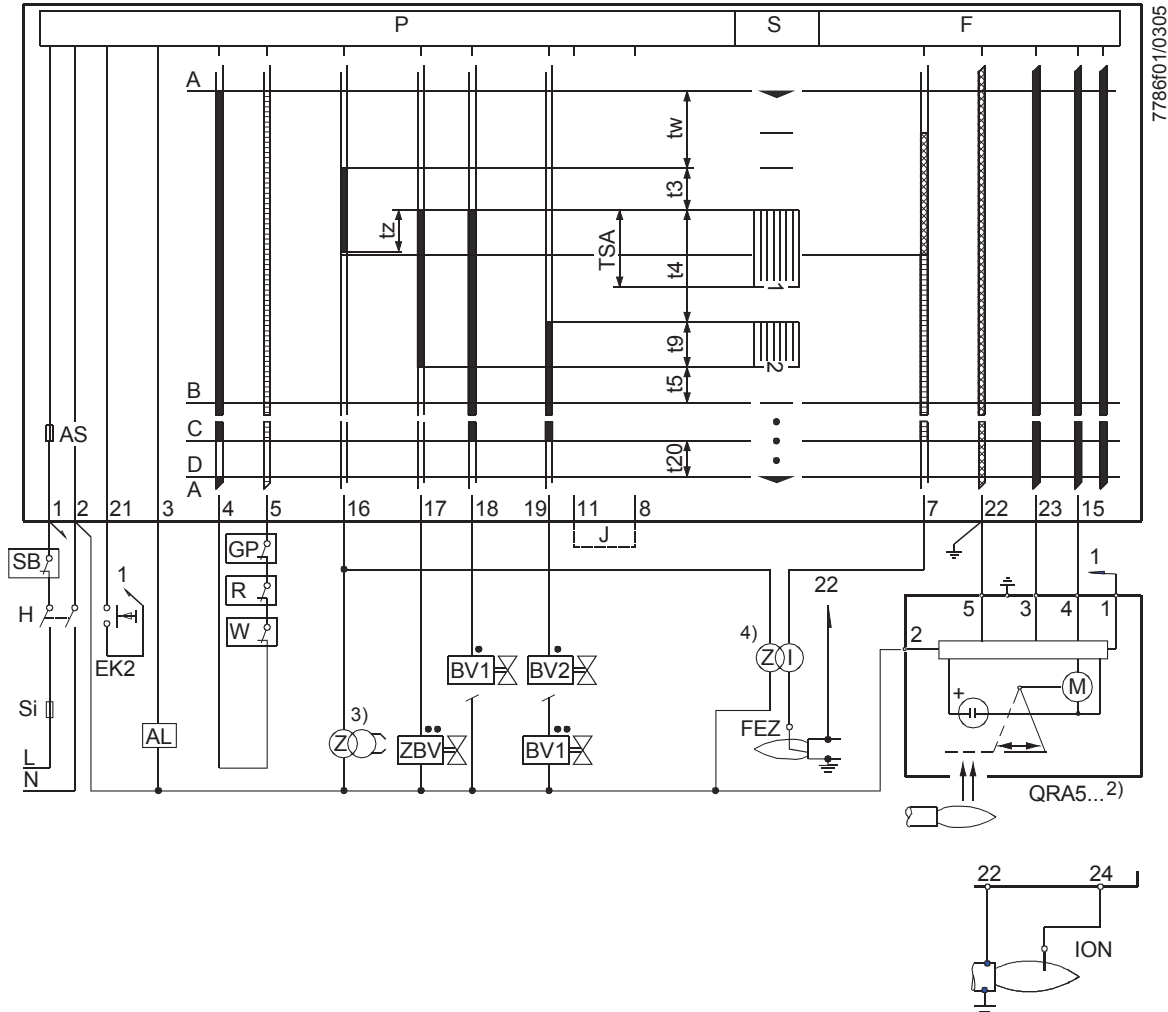

7786f01/0305



**Caution!**  
Do not press lockout reset button (EK...) for more than 10 seconds!

Legend

- Valid for expanding flame burner
- Valid for interrupted pilot burner

F Flame signal amplifier  
 P Programming mechanism  
 S Indication of program sequence in viewing window

TSA	Ignition safety time	5 s <sup>1)</sup>
tw	Waiting time	4.5 s <sup>1)</sup>
tz	Ignition time	2.5 s <sup>1)</sup>
t3	Preignition time	2.5 s <sup>1)</sup>
t4	Interval between start of release of the valve connected to terminal 17 or 18 and release of the valve connected to terminal 19	7,4 s <sup>1)</sup>
t5	Interval up to the self-shutdown of the programming mechanism in the operating position	
t9	Transition time from pilot burner to main burner second safety time (2. safety time (t9) plus safety time in operation)	3.5 s <sup>1)</sup>
t20	Home run time until the startup position after a controlled shutdown is reached	15 s <sup>1)</sup>

- 1) Data valid at 50 Hz, at 60 Hz, the times are 20 % shorter
- 2) When used in connection with QRA53... / QRA55..., terminal 22 must be earthed
- 3) Connection with separate ignition electrode and ionization probe (double-electrode operation)
- 4) Connection with common ignition electrode and ionization probe (single-electrode operation)

Control signals of burner control at nominal voltage  
 Required input signal  
 Terminal connected to earth

## Connection diagram and internal diagram

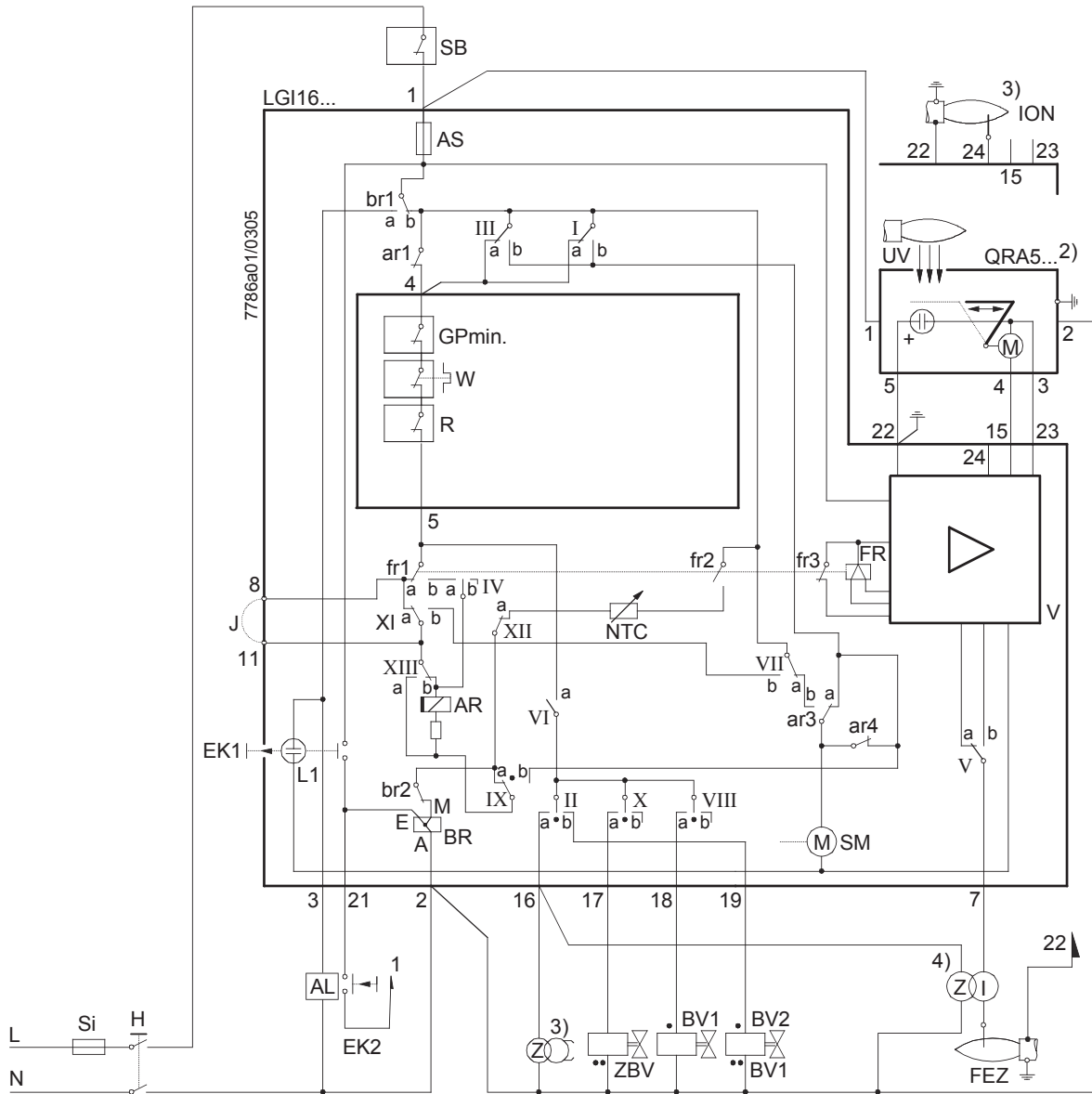



**Caution!**  
Do not press lockout reset button (EK...) for more than 10 seconds!

### Legend

- Valid for expanding flame burner
  - Valid for interrupted pilot burner
- 2) When used in connection with QRA53... / QRA55..., terminal 22 must be earthed
  - 3) Connection with separate ignition electrode and ionization probe (double-electrode operation)
  - 4) Connection with common ignition electrode and ionization probe (single-electrode operation)

## Legend

---

A	Start of program; control loop between terminals 4 and 5 closed
A – B	Startup program
B – C	Burner operation
C	Controlled shutdown; control loop between terminals 4 and 5 open
C – D	Home run of programming mechanism
D	Ready for restart
AL	Remote indication of lockout (alarm)
AR	Main relay (load relay) with contacts (ar)
AS	Unit fuse
BR	Lockout relay with contacts (br)
BV...	Fuel valve
EK...	Lockout reset button
ION	Ionization probe
FEZ	Ignition electrode and ionization probe
FR	Flame relay with contacts (fr)
GP	Gas pressure switch, minimum gas pressure switch
H	Main switch
J	Wire link between terminals 8 and 11 in the base of the LGI16..., in the event of loss of flame during operation: Wire link fitted: Lockout Without wire link: Automatic restart (repetition)
L1	Lockout warning lamp on the burner control
M	Fan motor
NTC	Resistor with negative temperature coefficient
QRA5...	Flame detector
R	Temperature or pressure controller
SB	Manual reset safety limiter
Si	External fuse
SM	Synchronous motor of programming mechanism
UV	UV radiation
V	Flame signal amplifier
W	Limit thermostat or pressure switch
Z	Ignition transformer for double-electrode operation
ZBV	Pilot gas valve
ZI	Ignition transformer for single-electrode operation
	Control signals delivered by the burner control
	Permissible input signals
	Terminal grounded

## Dimensions

Dimensions in mm

LGI16...

  
Plug-in base AGM15 / AGM15.1

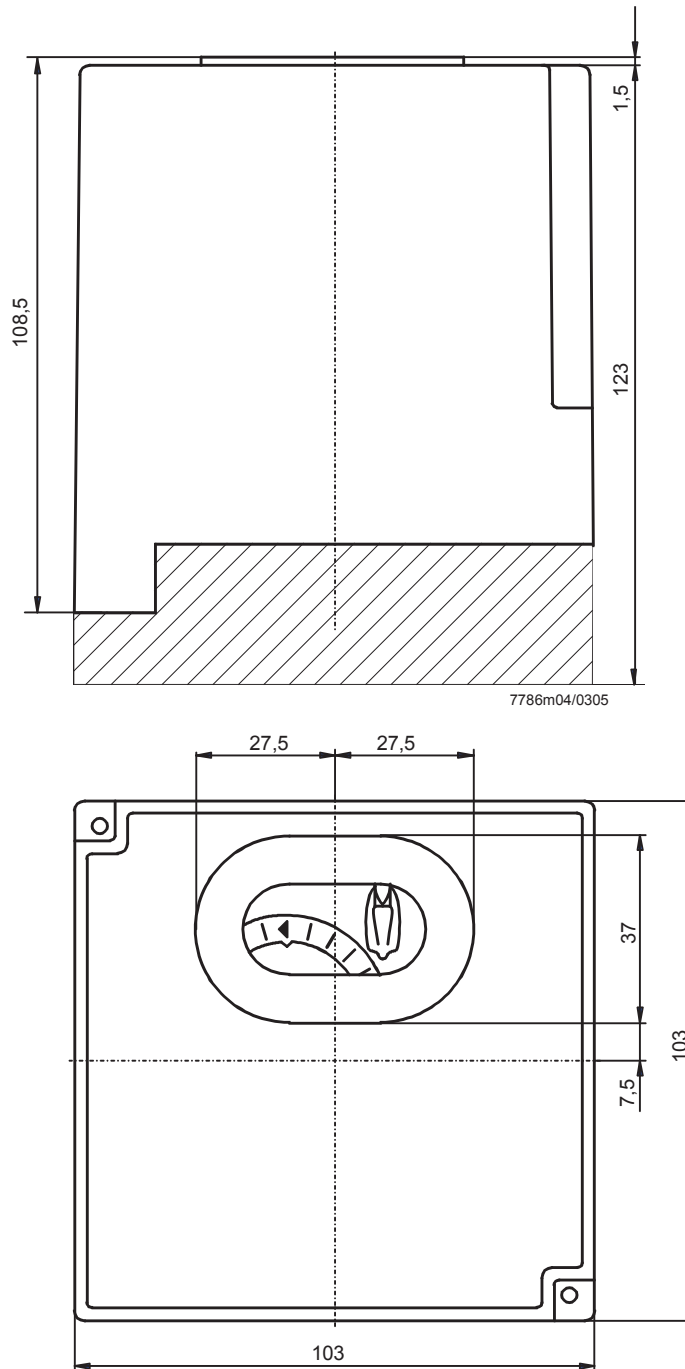

Distributor: FLAME POWER SRL 021-3121727 ; 0744-340566 [contact@arzatoare.ro](mailto:contact@arzatoare.ro) ; [www.arzatoare.ro](http://www.arzatoare.ro)

© 2013 Siemens AG Infrastructure & Cities Sector Building Technologies Products GmbH  
Subject to change!