

# SIEMENS

# 7<sup>781</sup>



## Flame Safeguards

## LAE10 LFE10

- Flame safeguards for burners with intermittent operation
- The LAE10 is used for the supervision and indication of oil flames
- The LFE10 is used for the supervision and indication of gas and oil flames
- Supplementary Data Sheets for flame detectors, refer to N7712 and N7713
- For control units LEC1 for continuous operation, refer to Data Sheet N7761

The LAE10 / LFE10 and this Data Sheet are intended for use by OEMs which integrate the flame safeguards in their products!

### Use

#### LAE10

- For the supervision of oil flames
- Flame supervision with silicon photocell detector RAR9...

#### LFE10

- For supervision of gas flames and luminous or blue-burning oil flames
- Flame supervision with flame detector QRA... or ionization probe

### General

Both types of flame safeguards are used primarily in conjunction with LEC1 control units on the following applications:

- **Dual-supervision of burners** / supervision of the main flame or of the ignition and main flame by 2 identical or different types of detectors
- **Supervision of forced draft oil / gas burners** / supervision of the flame with different types of detectors, depending on the operating mode
- **Multiflame supervision** / plants with several burners whose flames must be supervised individually by one or several detectors, whose startup and supervision, however, should or must be carried out centrally and simultaneously by only 1 burner control
- The flame safeguards can also be used in connection with other types of burner controls provided the given combination and selected connection circuit do not impair the burner control's safety functions
- The flame safeguards are also used as **flame indication units** in combustion plant with manual startup

## Warning notes

---



**The avoid injury to persons, damage to property or the environment, the following warning notes must be observed!**

**It is not permitted to open, interfere with or modify the units!**

- All activities (mounting, installation and service work, etc.) must be performed by qualified staff. If this is not observed, there is a risk of loss of safety functions or a risk of electric shock
- For safety reasons – self-test of flame supervision circuit, etc. – at least one controlled shutdown is required every 24 hours. If this is not observed, there is a risk of loss of safety functions
- Before making any wiring changes in the connection area, completely isolate the plant from mains supply (all-polar disconnection). Ensure that the plant cannot be inadvertently switched on again and that it is indeed dead. If not observed, there is a risk of electric shock hazard
- Ensure protection against electric shock hazard by providing adequate protection for the flame safeguard's connection terminals. If this is not observed, there is a risk of electric shock
- Each time work has been carried out (mounting, installation, service work, etc.), check to ensure that wiring is in an orderly state. If this is not observed, there is a risk of loss of safety functions or a risk of electric shock
- Fall or shock can adversely affect the safety functions. Such units must not be put into operation, even if they do not exhibit any damage
- The ionization probe does not offer protection against electrical shock hazard. The mains-operated ionization probe must be protected against accidental contact. If this is not observed, there is a risk of electric shock
- **An ignited UV tube is a source of UV radiation!** In case of flame supervision by means of flame detectors, the detectors must be placed such that there is **no direct visual contact** between them. If this is not observed, there is a risk of loss of safety functions

## Engineering notes

---

Ensure that the drop out delay time of relay «d» does not exceed 50 ms (also refer to «Connection examples», 7781a02).

## Mounting notes

---

- The relevant national safety regulations must be complied with
- The flame safeguards can be mounted in any position directly on the burner, in control panels, or on the front of a panel
- There are 2 types of plug-in bases available, designed for cable entry from the front, the side or below. 2 earth terminals provide looping facilities for the earth connections of other burner plant components such as ignition transformers (the flame safeguards themselves are double-insulated!)

## Installation notes

---

- Always run the high-voltage ignition cables separately while observing the greatest possible distances to the unit and to other cables
- Do not mix up live and neutral conductors

## Electrical connection of the detectors

It is important to achieve practically disturbance- and loss-free signal transmission:

- Never run the detector cable together with other cables
  - Line capacitance reduces the magnitude of the flame signal
  - Use a separate cable
- Ionization probe does not provide protection against electrical shock hazard
- Locate the ignition electrode and ionization probe such that the ignition spark cannot arc over to the ionization probe (risk of electrical overloads)
- Observe the maximum permissible lengths and shielding of the detector cables (refer to «Technical data»)
- Locate and adjust the detector such that only the flame to be supervised will be detected
- Protect the UV cell adequately against UV sources emitted by halogen lamps, welding equipments, special lamps, ignition sparks, high energy x-rays and gamma rays

## Standards and certificates



ISO 9001: 2008  
Cert. 00739



ISO 14001: 2004  
Cert. 38233

Only in combination  
with the flame detector



Conformity to EEC directives

- Electromagnetic compatibility EMC (immunity)
- Directive for gas appliances
- Directive for pressure devices

2004/108/EC  
2009/142/EC  
97/23/EC

			With LEC1...					
LAE10	x	x	x	x	x	---	x	---
LFE10	x	x	x	x	---	x	x	x

## Life cycle

Flame safeguards has a designed lifetime\* of 250,000 burner startup cycles which, under normal operating conditions in heating mode, correspond to approx. 10 years of usage (starting from the production date given on the type field). This lifetime is based on the endurance tests specified in standard EN230 / EN298 and the table containing the relevant test documentation as published by the European Association of Component Manufacturers (Afecor) ([www.afecor.org](http://www.afecor.org)).

The designed lifetime is based on use of the flame safeguards according to the manufacturer's Data Sheet. After reaching the designed lifetime in terms of the number of burner startup cycles, or the respective time of usage, the flame safeguards is to be replaced by authorized personnel.

\* The designed lifetime is not the warranty time specified in the Terms of Delivery

## Disposal notes



The flame safeguards contain electrical and electronic components and must not be disposed of together with household waste.  
Local and currently valid legislation must be observed.

## Mechanical design

---

The flame safeguards are of plug-in design and consist of power supply section, flame signal amplifier, flame relay, an auxiliary relay for controlling the flame detector or the flame simulation test, and a flame indication lamp located in the unit cover behind a viewing window.

The electrical circuit is intrinsically safe in connection with LEC1 control unit – is tested in respect of proper functioning each time the burner is started up. The plug-in bases – like the housing – are made of impact-proof and heat-resistant plastic. For illustrations of the plug-in bases and other notes, refer to «Dimensions».

Special features LAE10

Automatic light simulation test by increasing the sensitivity of the amplifier during the burner off and the purging times of the LEC1 control unit control.

Special features LFE10

Automatic testing of the flame detector by increasing the operating voltage of the UV tube during the burner off and the purging times of the LEC1 control unit.

### Flame supervision

Flame detector	Data Sheet
QRA2..., QRA10...	N7712
QRA4.U	N7711
RAR9...	N7713

Ionization probe

Flame supervision by making use of the electrical conductivity of the flame in conjunction with the rectifying effect is only possible with gas and blue-flame burners. Since the flame signal amplifier responds only to the DC component of the flame signal (ionization current), a short-circuit between flame detector and functional earth cannot simulate a flame signal.

## Type summary

---

### Flame safeguard

- For the supervision of oil flames with silicon photocell detectors RAR9...
- AC 220...240 V
- AC 110 V

**LAE10**  
**LAE10-110V**

### Flame safeguard

- For the supervision of gas / oil flames with flame detector QRA... or ionization probe
- AC 220...240 V
- AC 110 V

**LFE10**  
**LFE10-110V**

## Ordering

---

When ordering, please give complete type reference.

Flame safeguard is delivered **without plug-in base**; order these separately (refer to «Accessories»).

## Accessories

---

### Silicon photocell detectors RAR9...

refer to Data Sheet N7713

### UV flame detector QRA2..., QRA10...

refer to Data Sheet N7712

### UV flame detector QRA4.U

refer to Data Sheet N7711

### Ionization probe

supplied by thirds

### Low plug-in base (refer to «Dimensions»)

**AGK410413450**

- 10-pole screw terminals
- 5 cable entries

### High plug-in base (refer to «Dimensions»)

**AGK410490250**

- 10-pole screw terminals
- With removable front
- 6 cable entries, 4 of which with Pg11 thread

## Technical data

General unit data	Mains voltage	AC 220 V –15 %...AC 240 V +10 % AC 100 V –15 %...AC 110 V +10 %
	Mains frequency	50...60 Hz ±6 %
	Prefuse (external)	Max. 10 A (slow)
	Power consumption	4.5 VA
	Perm. contact rating	Max. 2 A
	Degree of protection	IP40, with appropriate cable entry
	Mounting position	Optional
	Cross sectional areas that can be connected to AGK4...	
	- Terminal 1...10	Min. 0,75 mm <sup>2</sup> Max. 1,5 mm <sup>2</sup> Solid wire or stranded wire with ferrule
	- Auxiliary terminals N, PE, 11 and 12	Min. 0,75 mm <sup>2</sup> Max. 1,5 mm <sup>2</sup> Solid wire or stranded wire with ferrule (when connecting 2 solid wires or stranded wires per terminal, same cross-sectional areas must be used)

<b>Weight</b>	<b>LAE10</b>	<b>LFE10</b>	
Without plug-in base	Approx. 305 g	Approx. 395 g	
With normal plug-in base	Approx. 380 g	Approx. 470 g	
With high plug-in base	Approx. 415 g	Approx. 505 g	
<b>Flame supervision with...</b>	<b>LAE10</b> ...RAR9...	<b>LFE10</b> ...Ionization probe ...QRA...	
Required detector current			
- At AC 100 V / AC 220 V	Min. 8 µA	Min. 8 µA	Min. 150 µA
- At AC 110 V / AC 240 V	Min. 8 µA	Min. 9 µA	Min. 200 µA
Possible detector current			
- At AC 100...110 V / AC 220...240 V	Max. 38 µA	Max. 100 µA	Max. 650 µA
<b>Perm. length of connecting cables</b>	20 m <sup>2)</sup>	20 m <sup>1)</sup>	20 m <sup>1)</sup>

<sup>1)</sup> In case of greater distances, use **low-capacitance** cable (total max. 2 nF)

*Example: Single-core RG62*

<sup>2)</sup> Run detector cables separately, at least 5 cm away from other cables

## Environmental conditions

<b>Storage</b>	DIN EN 60721-3-1
Climatic conditions	Class 1K3
Mechanical conditions	Class 1M2
Temperature range	-20...+60 °C
Humidity	<95 % r.h.
<b>Transport</b>	DIN EN 60721-3-2
Climatic conditions	Class 2K2
Mechanical conditions	Class 2M2
Temperature range	-20...+60 °C
Humidity	<95 % r.h.
<b>Operation</b>	DIN EN 60721-3-3
Climatic conditions	Class 3K5
Mechanical conditions	Class 3M2
Temperature range	-20...+60 °C
Humidity	<95 % r.h.



**Caution!**  
Condensation, formation of ice and ingress of water are not permitted!

## Technical data (cont'd)

### Measuring circuits

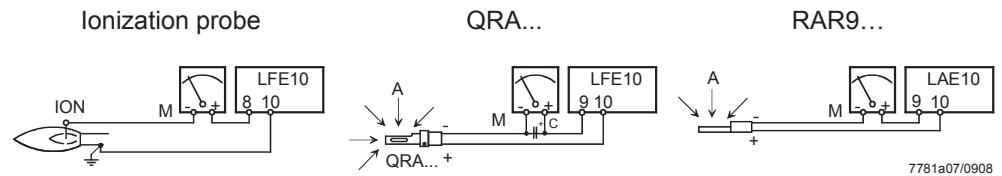

### Legend

A	Illumination of flame	ION	Ionization probe
C	Electrolytic capacitor 100 $\mu$ F, DC 10 V	M	Microammeter
		QRA...	Flame detector



#### Caution!

**Ignition may affect the ionization current!**

**Remedy: Exchange the connections on the primary side of the ignition transformer.**

### Function

Basic mode of operation of the flame safeguards in connection with the LEC1 control unit:

When used with the LEC1, the flame safeguard feeds the flame signal into the burner control's control program the same way as if the flame safeguard was a component of the burner control (same as with an oil or gas burner control). In the event of non-ignition, loss of flame during burner operation or faulty flame signal during burner off or purging times, the burner will always be shut down and the burner control will initiate lockout. The switching functions needed to feed the flame signal into the burner control's control circuit are provided by flame relay «FR» of the flame safeguard and the 2 auxiliary relays «HR1» and «HR2» of the LEC1 control unit. The LEC1 control unit also delivers the sequence control for the flame simulation test in connection with the LAE10 flame safeguard, and the flame detector test with the LFE10. The test is controlled via the connecting line between terminal 15 of the burner control and terminal 6 of the respective flame safeguard.

#### Both tests

- start about 7 seconds after a controlled shutdown
- are continued during burner off times
- Are continued during the ensuing prepurge time
- end 3 seconds before start of the safety time

Following flame signals during this test time lead to lockout with interlocking of the LEC1 control unit:

- Extraneous light
- Ageing flame detectors
- Other defects of the flame supervision equipment

In the flame safeguard, the switching functions required are performed by auxiliary relay «HR3».

Since in the case of flame supervision with an ionization probe, it is not necessary to carry out a test, the connecting line between terminal 15 of the burner control and terminal 6 of the flame safeguard is not required here.



#### Information!

Instead, terminal 6 must be connected to the live wire.  
*Example: By making a connection to terminal 1, 5 or 7.*

Any flame signal – be it a normal flame signal during operation or a faulty signal – is indicated by the indication lamp at housing of flame safeguard.

**Mode of operation of the flame safeguards when used for dual-supervision** (detailed connection diagram, e.g. for oil burners)

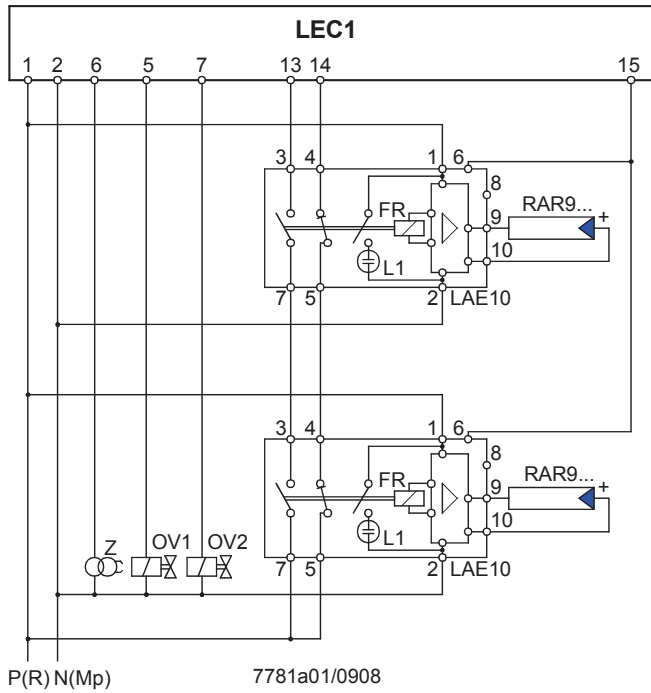

With this type of supervision, **1** flame is supervised by **2** independently operating flame safeguards, aimed at reducing the possibility of loss of flame during operation in case of a simultaneous failure of **both** flame safeguards to an «improbable coincidence».

With dual-supervision, the control contacts of the flame relays of both flame safeguards are connected in series so that loss of the **flame signal of either of the flame safeguards is sufficient** to cause lockout of the burner. A faulty flame signal by only **1** of the 2 flame safeguards during burner off times or purging times also leads to lockout.



## Mode of operation of the flame safeguards when used for the supervision of 2 manually controlled burners

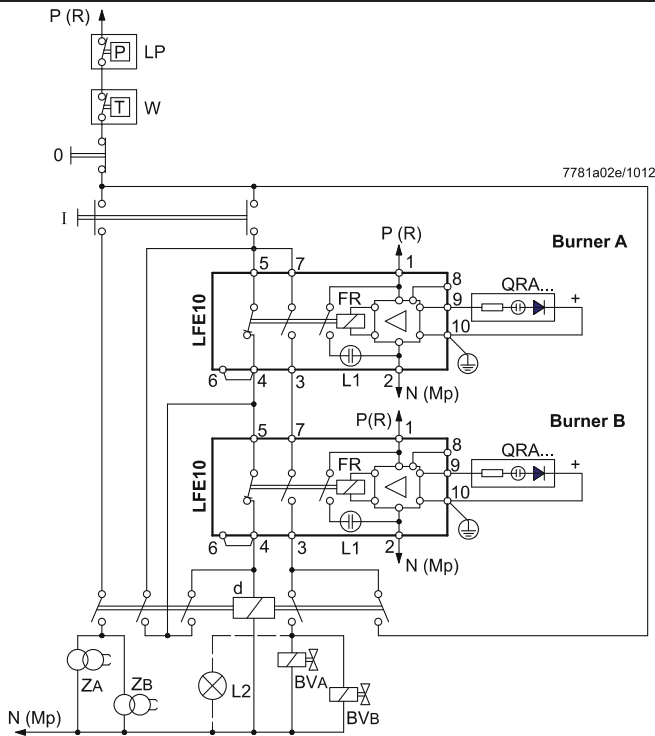

With this type of supervision, too, the burner can be started only if the flame detector or flame simulation test has been successful. This means that **neither** of the 2 flame safeguards may detect a flame signal during burner off times. When the burner is started up, the detector test will automatically be interrupted.

When pressing button «I», relay «d» is energized via circuit path 4-5 of the flame relays, which is still closed, thus switching on the ignition of both burners.

At the same time, fuel is released.

The duration of the start pulse given by pressing button «I» should be limited by a time relay – in the sense of a **safety time**.

If the flame is established on **both** burners - indicated by the signal lamps at housing of flame safeguards – relay «d» is now maintained in its energized condition via circuit path 3-7 of the 2 flame relays.

When releasing button «I», ignition will be switched off, thus completing the startup sequence.

If the event of loss of flame on **1** of the burners, the respective flame relay is deenergized, thereby neutralizing the holding circuit for relay «d». This means that the fuel valves of **both** burners will immediately be shut.

The burners are switched off manually by pressing button «0», or – automatically – by the control / limit thermostat or pressurestat / pressure switch in the phase wire connection.

In case of flame supervision with ionization probes, terminal 6 of the flame safeguards must be connected directly to the phase wire since no detector test is required here.

*Example: During connection with terminal 1!*



### Note!

Ensure that the drop out delay time of relay «d» does not exceed 50 ms (also refer to «Connection examples», 7781a02).



### Caution!

**An ignited UV tube is a source of UV radiation!** In case of flame supervision by means of flame detectors, the detectors must be placed such that there is **no direct visual contact** between them. If this is not observed, there is a risk of loss of safety functions

**Mode of operation of the flame safeguards with multi-flame supervision** (detailed connection diagram, e.g. for gas burners)

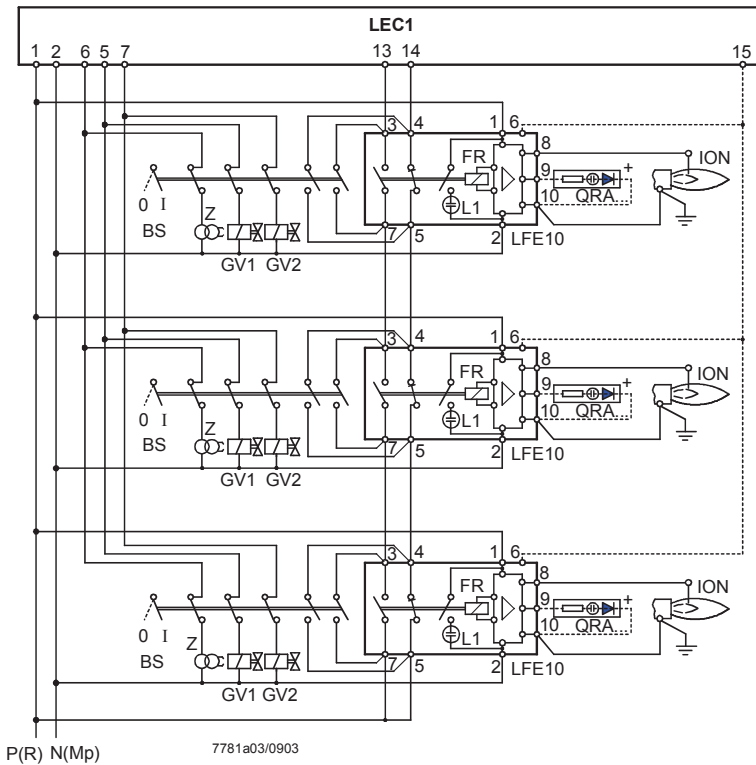

Like with dual-supervision, the control contacts of the flame relays of all flame safeguards must be connected in series when using multi-flame supervision.

A burner causes all other burners to go to lockout if:

- the flame is not established during the safety time, or
- the flame is lost during operation.

Correctly operating burners can be restarted only – after the burner control has been reset – when the faulty burner has been shut down. In that case, the operating switch must not only bridge the control contacts of the respective flame safeguards, thus closing the control chain again, but must also break the phase wire connection to the ignition transformer and the fuel valves.

Likewise, after rectification of the fault, the burner can only be restarted in connection with the other burners, that is, only after all burners have previously been shut down.



**Caution!**  
Terminal 10 must be connected to earth also when using the flame detector QRA...!

**Legend**

- BS Operating switch OFF / ON → per burner
- ION Ionization probe for ionization supervision
- FR Flame relay
- GV1 / GV2 Gas valve for 1<sup>st</sup> and 2<sup>nd</sup> stage
- L1 Built-in signal lamp → indication of flame
- QRA... Flame detector
- Z Ignition transformer

**Basic circuit diagrams**

**LFE10 with flame detector QRA**

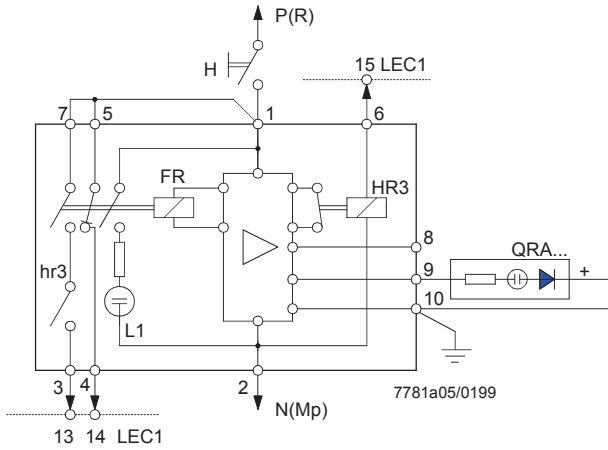

**Caution!**  
Terminal 10 must be connected to earth!

**LFE10 with ionization supervision**

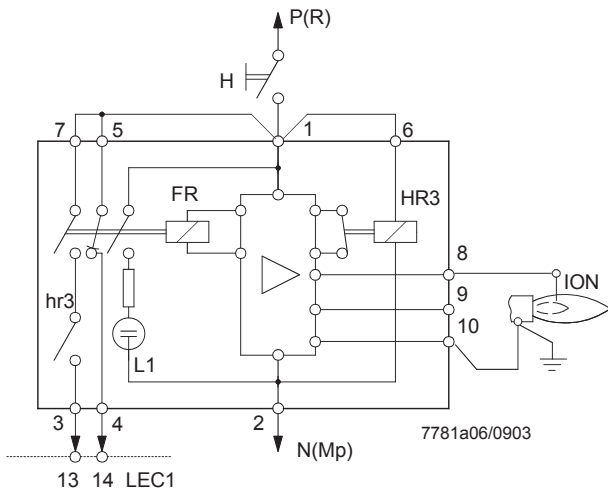

**LAE10 with silicon photocell detector RAR9...**

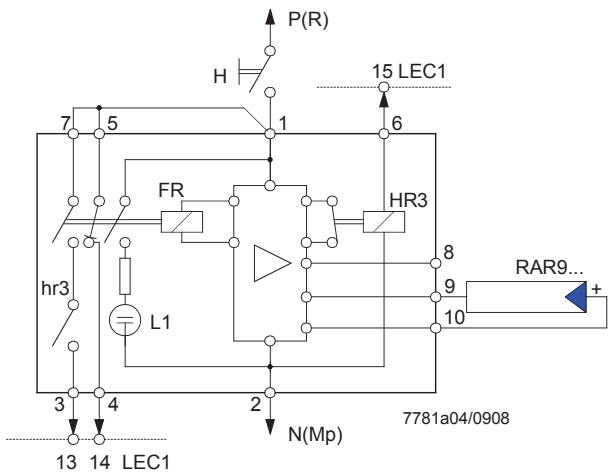

**Legend**

- FR Flame relay
- H Main switch
- HR3 Auxiliary relay for UV detector or flame simulation test
- ION Ionization probe for ionization supervision
- L1 Built-in signal lamp  
→ Indication of flame
- QRA... Flame detector
- RAR9... Silicon photocell detector

## Dimensions

Dimensions in mm

### Base versions

Low plug-in base,  
**AGK 4 104 1345 0**

#### Design features:

10-pole (screw terminals), with additional earth terminals. Cable entry either through the bottom of the base (2 knockout holes), the front, from the right or left side (total of 5 cable entries).

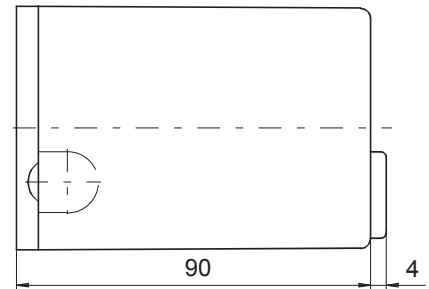
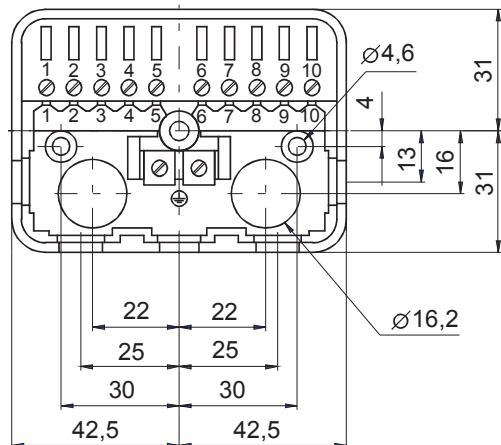
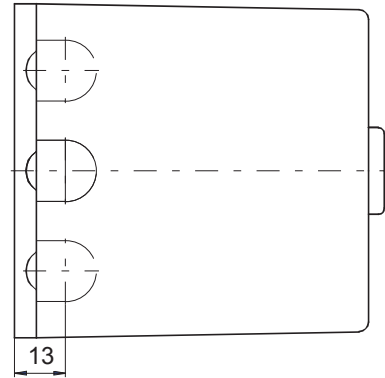
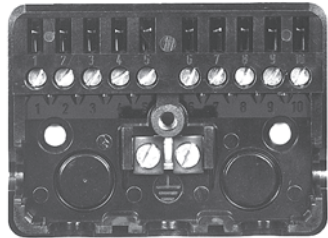

7781m02/1198

## Dimensions (cont'd)

Dimensions in mm

### Base versions

High plug-in base,  
**AGK 4 104 9025 0**

#### Design features:

With removable front (shaded area in the drawing).

10-pole (screw terminals), and:

- 2 auxiliary terminals with markings 11 and 12
- 2 neutral terminals, wired to terminal 2 (neutral input)
- 2 earth terminals, with earthing lug for the burner

For cable entry:

- 2 cable entries in the bottom of the base
- 4 threaded knockout holes for cable glands Pg11, 1 on the right, 1 on the left, and in the **removable front**

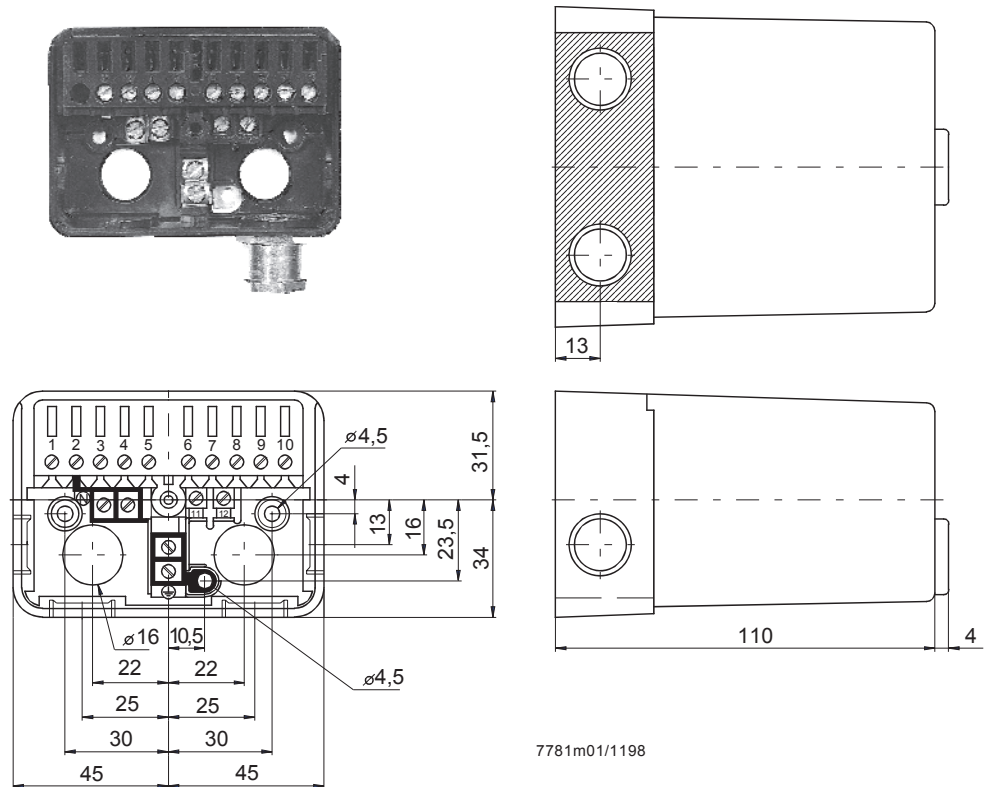

Distributor: FLAME POWER SRL 021-3121727 ; 0744-340566 [contact@arzatoare.ro](mailto:contact@arzatoare.ro) ; [www.arzatoare.ro](http://www.arzatoare.ro)

©2012 Siemens AG Infrastructure & Cities Sector Building Technologies Division  
Subject to change!

13/13