

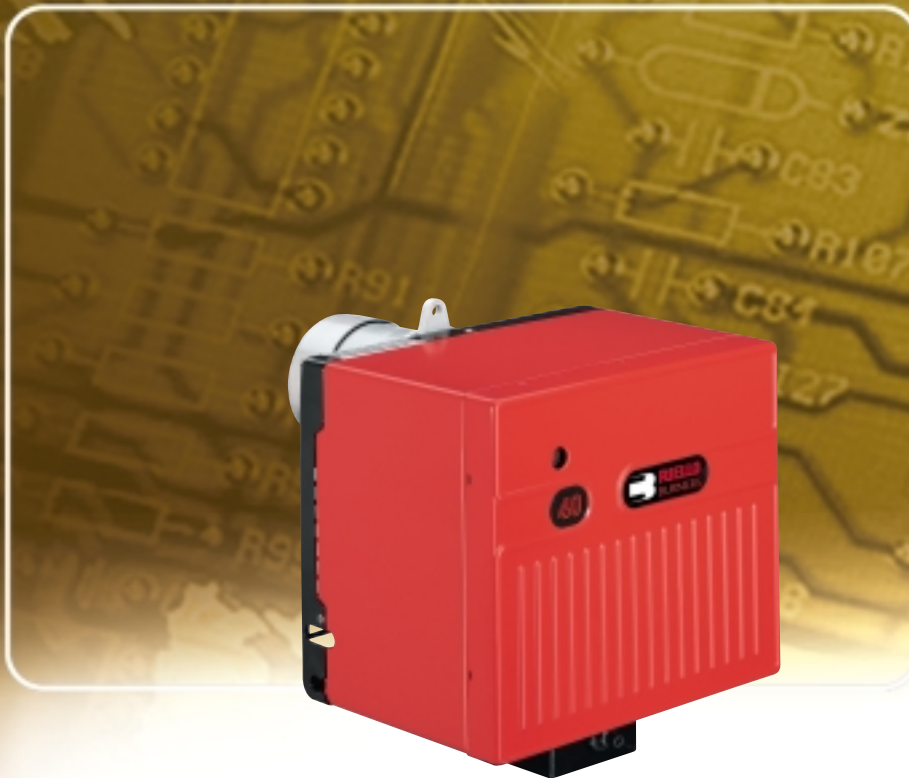

ONE STAGE HEAVY OIL BURNERS

▶ **RIELLO 40 N SERIES**

▶ N10	34 ÷ 102	kW
▶ N20	102 ÷ 217	kW



The Riello 40 N series of one stage heavy oil burners, is a range of products developed to respond to any request for home heating. The Riello 40 N series is available in two different models, with an output ranging from 34 to 217 kW, divided in two different structures. All the models use the same components designed by Riello for the Riello 40 N series. The high quality level guarantees safe working.

In developing these burners, special attention was paid to the ease of installation and adjustment, to obtaining the smallest size possible to fit into any sort of boiler available on the market.

All the models are conform to European Directives for EMC, Low Voltage and Machinery. All the Riello 40 N burners are tested before leaving the factory.

TECHNICAL DATA

Model		▼ N10	▼ N20
Burner operation mode		One stage	
Modulation ratio at max. output		--	
Servo-motor	type	--	
	run time	s	
Heat output	kW	34 - 102	102 - 217
	Mcal/h	29,4 - 88,2	88,2 - 186,2
	kg/h	3 - 9	9 - 19
Working temperature	°C min./max.	0/40	
Net calorific value	kWh/kg	11,4	
	kcal/kg	9800	
Viscosity	mm²/s (cSt)	25 - 50 (at 50°C)	
Pump	type	SUNTEC	
	delivery	kg/h	
Atomised pressure	bar	16-28	
Fuel temperature	max. °C	50	
Fuel pre-heater		NO	
Fan	type	centrifugal with forward curve blades	
Air temperature	max. °C	40	
Electrical supply	Ph/Hz/V	1/50/230±10%	
Auxiliary electrical supply	Ph/Hz/V	--	
Control box	type	LANDIS LOA 22	
Total electrical power	kW	1,1	1,8
Auxiliary electrical power	kW	--	
Heaters electrical power	kW	--	
Protection level	IP	40	
Pump motor electrical power	kW	--	
Rated pump motor current	A	--	
Pump motor start up current	A	--	
Pump motor protection level	IP	--	
Fan motor electrical power	kW	0,14	0,30
Rated fan motor current	A	0,85	1,5
Fan motor start up current	A	3,5	6
Fan motor protection level	IP	20	
Ignition transformer	type	Incorporated in the control box	
	V1-V2	5 kV	
	I1-I2	30 mA	
Operation		intermittent (at least one stop every 24h)	
Sound pressure	dB(A)	65	74
Sound power	W	--	
CO emission	mg/kWh	<60	
Grade of smoke indicator	N° Bach.	4 - 6	
C_xH_y Emissions	mg/kWh	<10 (after the first 20s)	
NO_x Emissions	mg/kWh	<600	
Directive		89/336/EEC, 73/23/EEC, 89/392/EEC	
Conforming to		--	
Certification		--	

Reference conditions:

Temperature: 20 °C

Pressure: 1013.5 mbar

Altitude: 100 m a.s.l.

Noise measured at a distance of 1 meter.

Since the Company is constantly engaged in the production improvement, the aesthetic and dimensional features, the technical data, the equipment and the accessories can be changed.

This document contains confidential and proprietary information of RIELLO S.p.A. Unless authorised, this information shall not be divulged, nor duplicated in whole or in part.



FIRING RATES

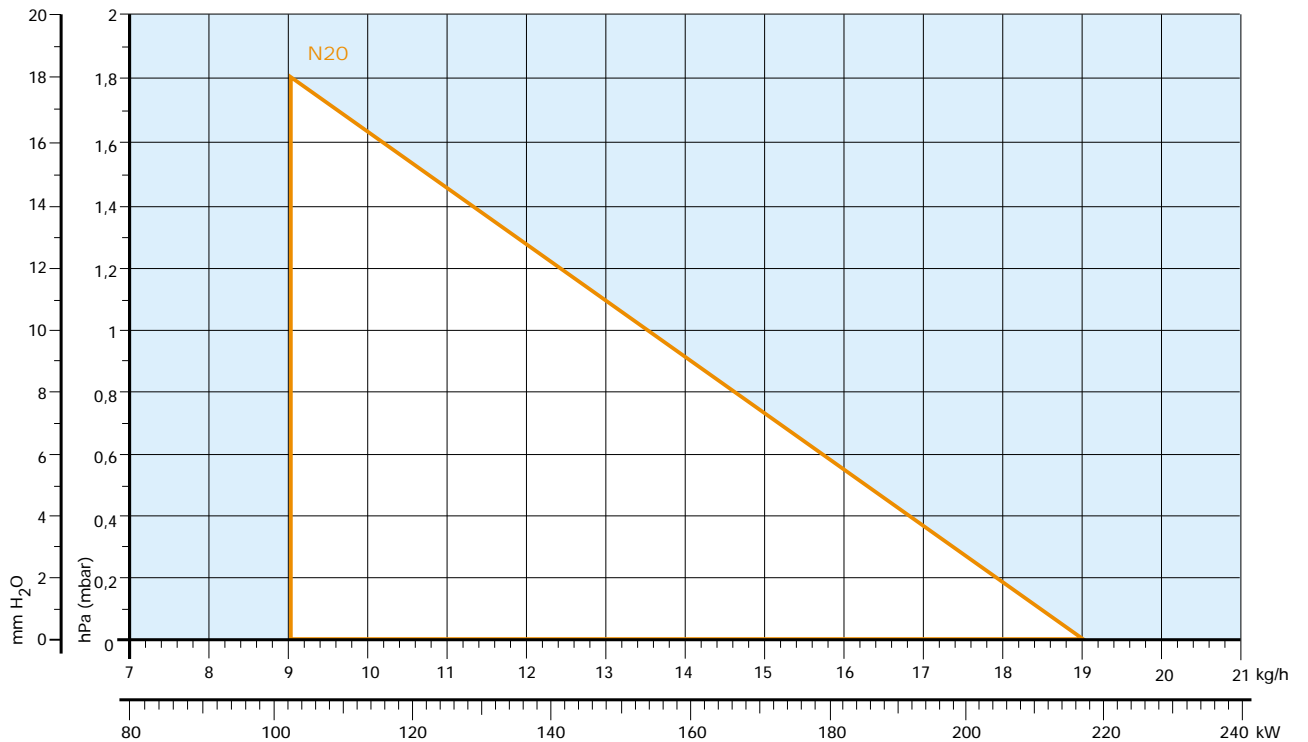
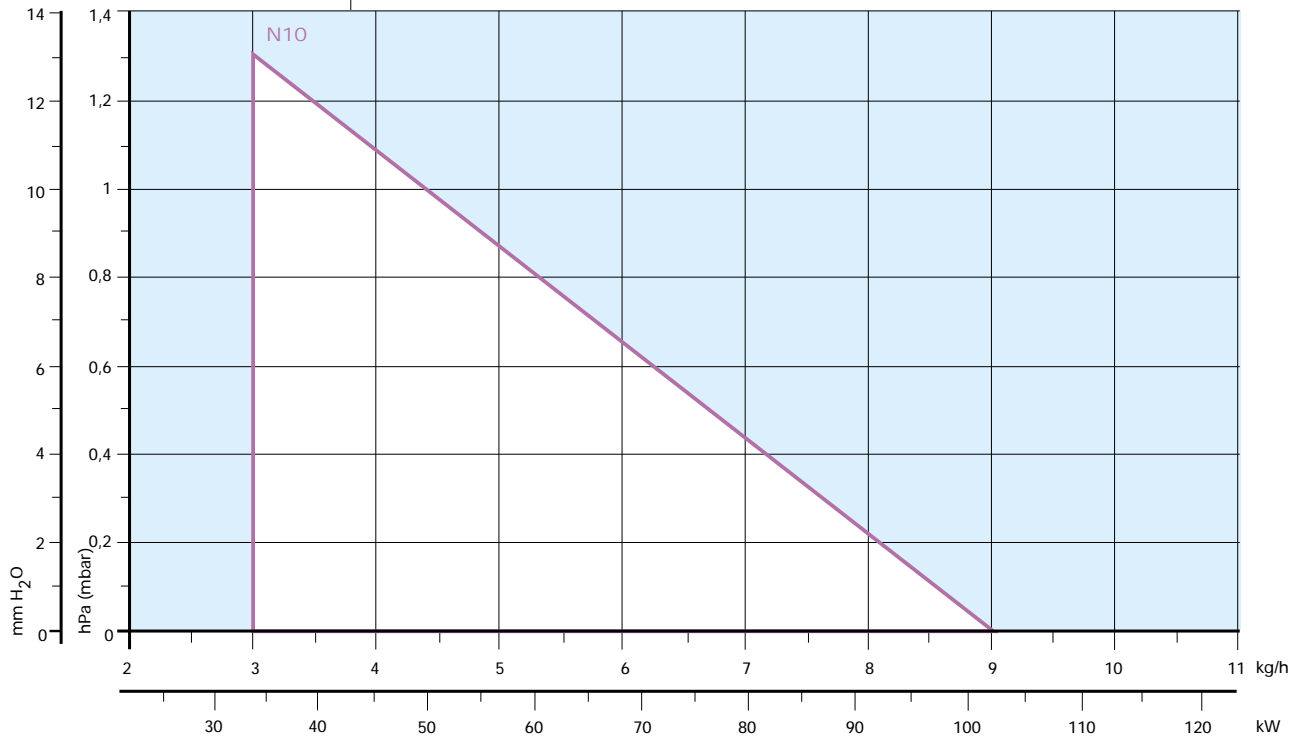

Useful working field for choosing the burner

Test conditions:
Temperature: 20°C
Pressure: 1013.5 mbar
Altitude: 100 m a.s.l.



FUEL SUPPLY

HYDRAULIC CIRCUIT

All the burners have a Suntec geared pump with safety valve on the return circuit.



Fuel pump

N10 - N20

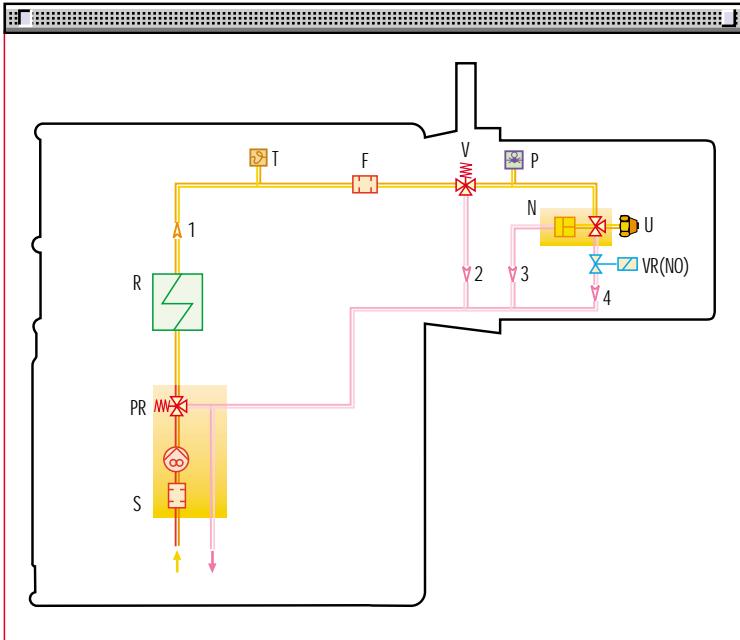

S	Pump with filter and pressure regulator on the delivery pipe
PR	Pressure oil regulator
R	Pre-heater
T	Thermostat
F	Filter
V	Degassing valve
P	Pressure gauge
N	Nozzle holder
U	Nozzle
VR(NO)	Oil return valve (usually open) on the delivery pipe
1	Oil input pipe to the nozzle
2	Oil return pipe from the degassing valve
3	Oil return pipe from the nozzle holder
4	Oil return pipe during pre-washing

Fuel feed to the burner can be from the right or the left side on all models.

HEAVY OIL PRE-HEATER

This burner series is provided with a electrical oil pre-heater included in the burner housing constantly on.



SELECTING THE FUEL SUPPLY LINES

The fuel feed must be completed with the safety devices required by the local regulations in force.

The table shows the choice of piping diameter for the various burners, depending on the difference in the height between the burner and the tank and the distance between them.

MAXIMUM EQUIVALENT LENGTH OF THE PIPEWORK L[m]				
Pipe size	Type A system		Type B system	
	Ø 1 1/4"	Ø 1 1/2"	Ø 3/4"	Ø 1"
H (m)	L _{max} (m)	L _{max} (m)	L _{max} (m)	L _{max} (m)
0	22	45	10	20
0,5	19	39	14	26
1,0	16	33	18	32
1,5	13	27	22	38
2,0	10	21	26	44
2,5	7	15	-	-
3	0	8	-	-

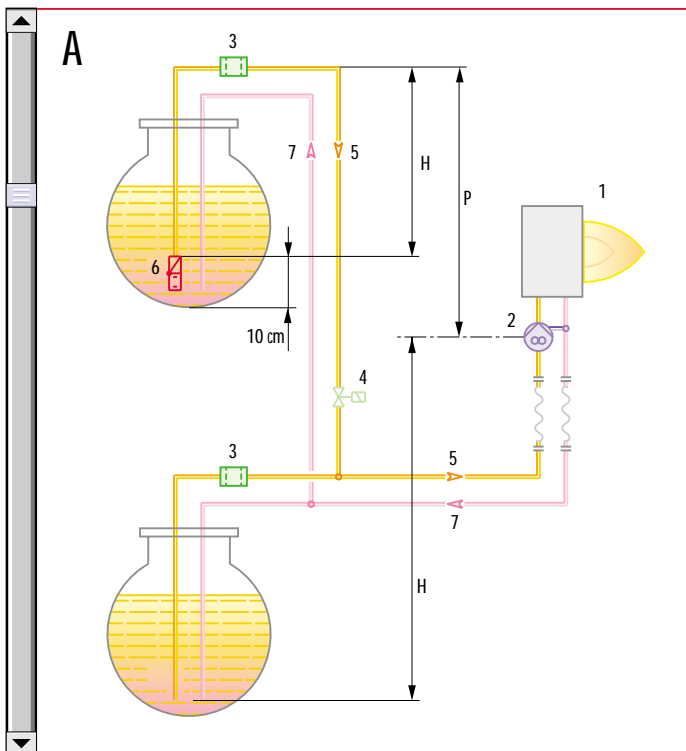

Type of system that can be installed

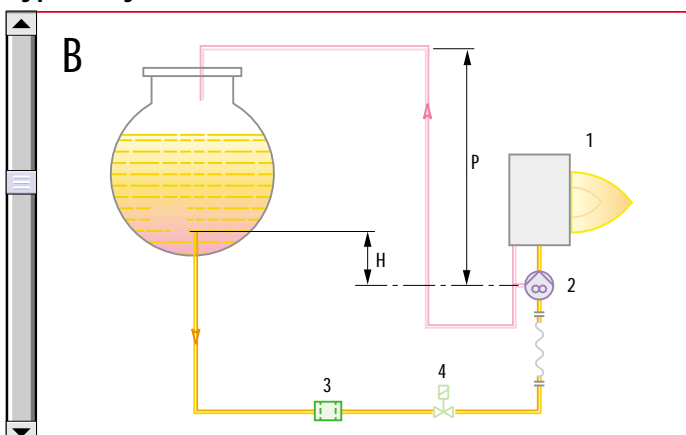

H	Difference in height
Ø	Internal pipe diameter
P	Difference in height ≤ 10 m
1	Burner
2	Pump
3	Filter
4	Shut-off solenoid valve
5	Suction pipework
6	Bottom valve
7	Return pipework



VENTILATION

The ventilation circuits always ensure low noise levels with high performance of pressure and air delivery, inspite of their compact size.



Air suction



COMBUSTION HEAD

Simple adjustment to the combustion head allows adapting internal geometry of the head to the maximum rated output of the burner.

The following diagram shows the flame dimensions in relation to the burner output. The length and diameter shown in the diagram below should be employed for a preliminary check: it is required a more careful investigation if combustion chamber dimensions are much different from the above reported values.



Combustion head

Dimensions of the flame

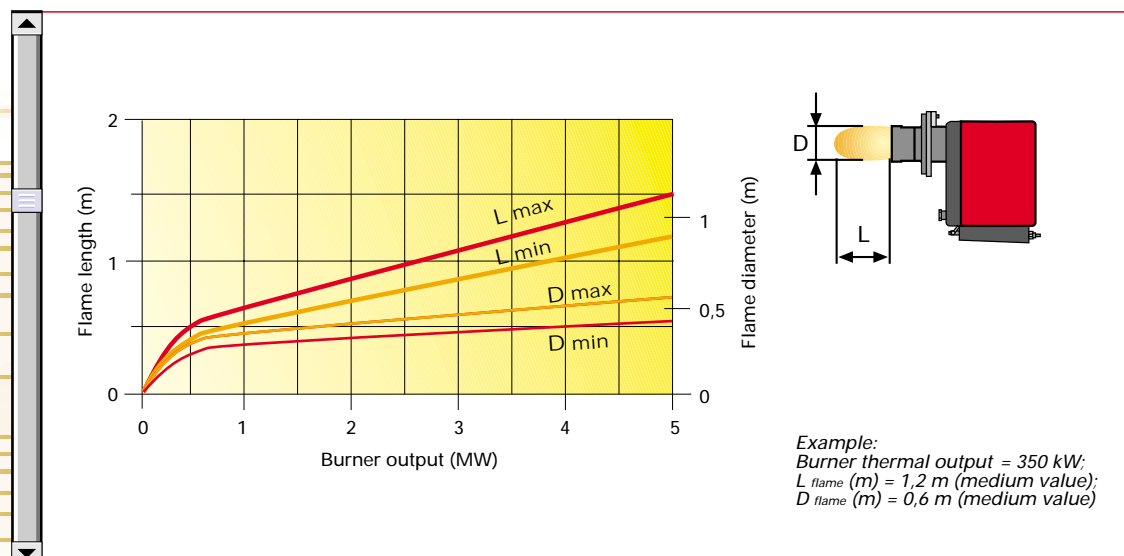

ADJUSTMENT



BURNER OPERATION MODE

The models are one stage operation.



Air damper

One stage operation

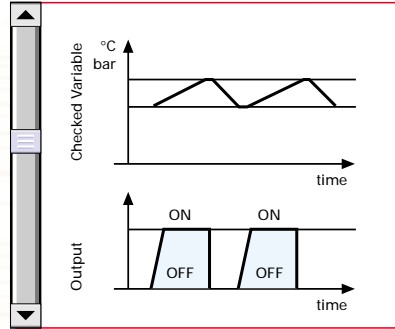

START UP CYCLE

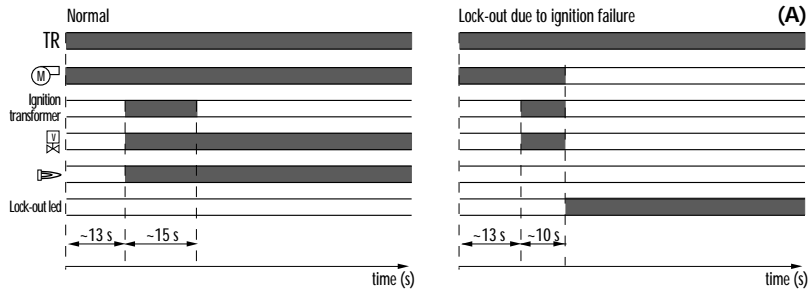

(A) Lock-out is shown by a led on the appliance.

Correct operation

- 0s The burner begins the ignition cycle.
- 0s-13s Pre-purge.
- 13s Ignition.

Lock-out due to ignition failure

If the flame does not light within the safety limit (~10s) the burner locks-out.



WIRING DIAGRAMS

Electrical connections must be made by qualified and skilled personnel, in conformity with the local regulations in force.



Control box and separated ignition transformer

▶ "ONE STAGE" OPERATION

N10 - N20

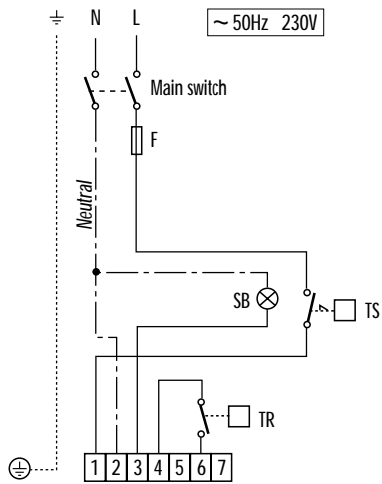

TR - Regulating thermostat
 TS - Safety thermostat (with manual resetting)
 SB - Remote lock-out lamp (230V 0,5A max)
 F - Fuse

The following table shows the supply lead sections and types of fuse to be used.

Model	▼ N10	▼ N20
	230V	230V
F A	6	T6
L mm ²	1	1

EMISSIONS

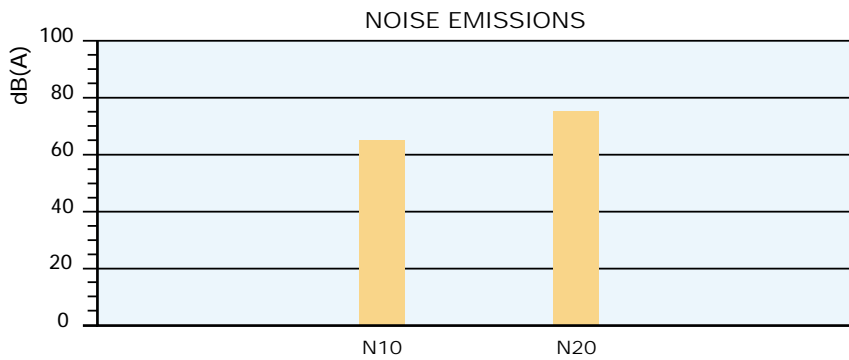
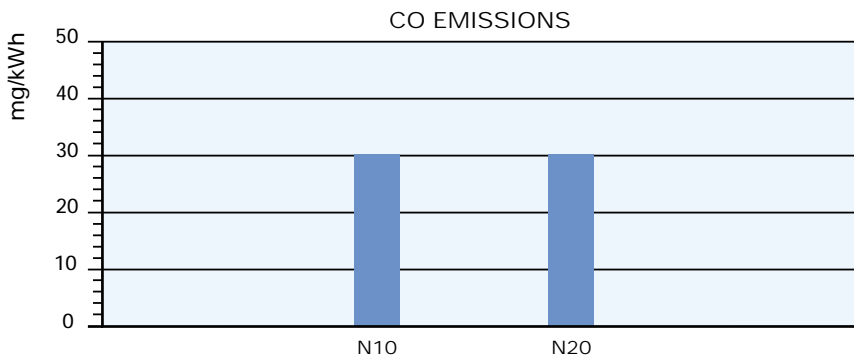
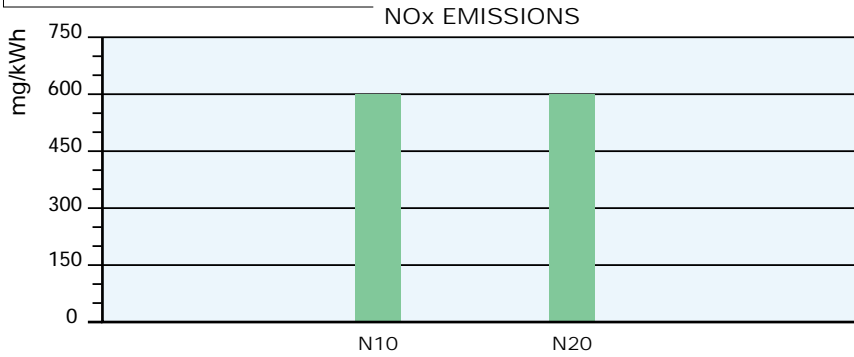

The emission data has been measured in the various models at maximum output.

Special attention has been paid to noise reduction. All models are fitted with sound-deadening material inside the cover.





OVERALL DIMENSIONS (mm)

BURNER

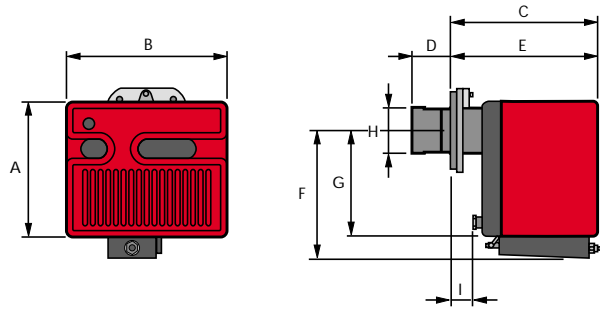

Model	A	B	C	D	E	F	G	H	I
► N10	262	305	275	108	261	258	204	105	25
► N20	298	350	-	118	295	280	230	125	35

BURNER - BOILER MOUNTING FLANGE

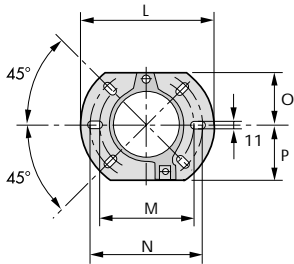

Model	L	M	N	O	P
► N10	189	140	170	83	83
► N20	213	160	190	99	99

PACKAGING

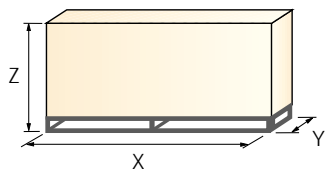

Model	X	Y	Z	kg
► N10	395	307	375	26
► N20	425	352	410	29

INSTALLATION DESCRIPTION



Skilled and qualified personnel must perform installation, start up and maintenance. A nozzle is fitted to the burner and used for tests in the factory. If necessary, change the nozzle on the basis of the maximum output of the boiler.
All operations must be carried in accordance with the technical handbook supplied with the burner.



BURNER SETTING

- ▶ Air damper and head adjustment area are easily accessible and the operation is simple thanks to a graduated scale and following the manual instruction.

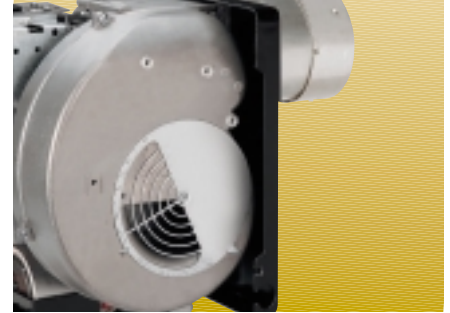

- ▶ The heavy oil vaporisation can be improved adjusting the fuel temperature by a screw fitted on the adjustment thermostat.



MAINTENANCE

- ▶ The maintenance position is easily carried out by hinge that joins the body of burner to the flange.

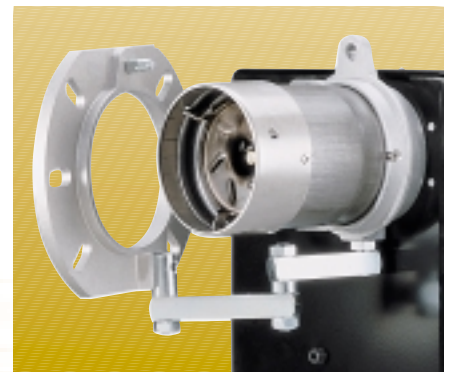



BURNER ACCESSORIES

Heavy oil filter

Heavy oil filter	
Burner	Kit code
N10 - N20	3004588

Self cleaning filter

Self cleaning filter	
Burner	Kit code
N10 - N20	3000861

SPECIFICATION



A special index will help you choose the right burner from the Riello 40 N models available. There is also a clear and detailed product specification and description.

DESIGNATION OF SERIES

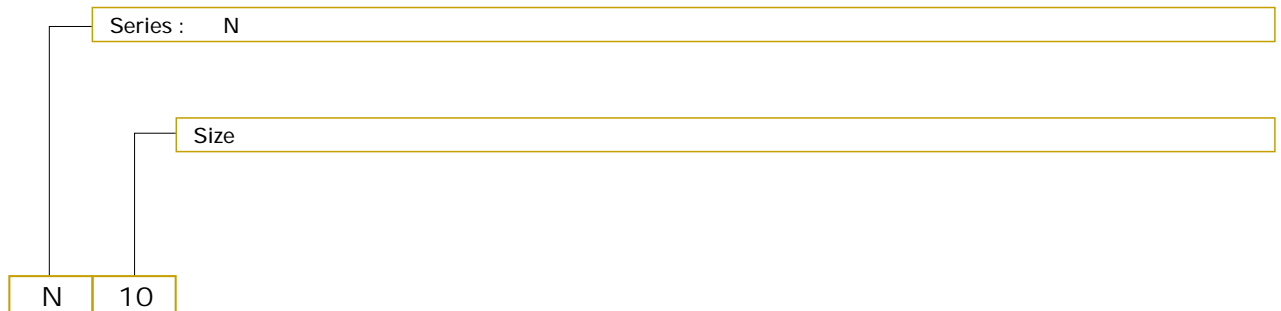

AVAILABLE BURNER MODELS

N10	34 ÷ 102	kW
N20	102 ÷ 217	kW



▶ PRODUCT SPECIFICATION

Burner:

Completely automatic monobloc heavy oil burners, with one stage operation fitted with:

- Fan with forward inclined blades
- Metallic cover
- Air damper with adjustment
- Single phase electric motor 230 V, 50 Hz
- Combustion head fitted with:
 - stainless steel head cone, resistant to high temperatures
 - ignition transformer
 - flame stability disk
- Geared pump for fuel supply, fitted with:
 - filter
 - pressure regulator
 - attachments for fitting a pressure gauge and vacuum meter
- Fuel feed solenoid valve incorporated in the pump
- Photocell for flame detection
- Electronic flame control equipment
- Heavy oil nozzle
- Heavy oil pre-heater
- Pressure gauge
- Thermostat with adjustment
- IP 40 protection level.

Conforming to:

- Directive 89/336/EEC (electromagnetic compatibility)
- Directive 73/23/EEC (low voltage)
- Directive 89/392/EEC (machinery).

Standard equipment:

- Two flexible pipes for connection to the heavy oil supply line
- Two nipples for connection to the pump
- Flange, screws and nuts for fixing
- Thermal screen
- Grommet
- Nozzle
- Instruction handbook for installation, use and maintenance
- Spare parts catalogue
- Hinge
- Seal for flexible tubes.

Available accessories to be ordered separately:

- Heavy oil filter
- Self-cleaning filter.



RIELLO S.p.A. - Via degli Alpini, 1 - 37045 LEGNAGO (VR) Italy
Tel. ++39.0442630111 - Fax ++39.044221980

Internet: <http://www.rielloburners.com> - E-mail: rburners@rielloburners.com



Since the Company is constantly engaged in the production improvement, the aesthetic and dimensional features, the technical data, the equipment and the accessories can be changed.
This document contains confidential and proprietary information of RIELLO S.p.A.
Unless authorised, this information shall not be divulged, nor duplicated in whole or in part.